

SOKKIA

Series20K

SET220K

SET320K

SET520K

SET620K

Electronic Total Station



Class 1 Laser Product

OPERATOR'S MANUAL



Li-ion

CONTAINS Li-ion BATTERY.
MUST BE RECYCLED OR DISPOSED OF PROPERLY.

JSIMA

:This is the mark of the Japan Surveying
Instruments Manufacturers Association.

SOKKIA

Series20K

SET220K

SET320K

SET520K

SET620K

Electronic Total Station

Class 1 Laser Product

OPERATOR'S MANUAL

- Thank you for selecting the SET220K/320K/520K/620K.
- Please read this operator's manual carefully before using this product.
- Verify that all equipment is included.
☞ "28.1 Standard Equipment"
- SET has a function to output data saved in the SET to a connected host computer. Commands operations from a host computer can also be performed. For details, refer to "Interfacing with the SOKKIA SDR Electronic Field Book" and "Command Explanations" manuals and ask your local dealer.
- The specifications and general appearance of the instrument are subject to change without prior notice and without obligation by Sokkia Topcon Co., Ltd. and may differ from those appearing in this manual.
- The content of this manual is subject to change without notice.
- Some of the diagrams shown in this manual may be simplified for easier understanding.

HOW TO READ THIS MANUAL

Symbols

The following conventions are used in this manual.



: Indicates precautions and important items which should be read before operations.



: Indicates the chapter title to refer to for additional information.



: Indicates supplementary explanation.





: Indicates an explanation for a particular term or operation.

[DIST] etc. : Indicates softkeys on the display.

{ESC} etc. : Indicates operation keys on the SET or wireless keyboard.

<S-O> etc. : Indicates screen titles.

Notes regarding manual style

- Screens and illustrations appearing in this manual are of SET220K.
- Location of softkeys in screens used in procedures is based on the factory setting. It is possible to change the allocation of softkeys in Meas Mode.
 What are softkeys: "4.1 Parts of the Instrument", Softkeys allocation: "25.2 Allocating Key Functions"
- Learn basic key operations in "BASIC OPERATION" before you read each measurement procedure.
- Measurement procedures are based on continuous measurement. Some information about procedures when other measurement options are selected can be found in "Note" ()
- For selecting options and inputting figures, see "5.1 Basic Key Operation".

READ THIS
FIRST

- 1. PRECAUTIONS FOR SAFE OPERATION 1
- 2. PRECAUTIONS 5
- 3. LASER SAFETY INFORMATION 8

INTRODUCTION

- 4. SET FUNCTIONS 9
 - 4.1 Parts of the Instrument 9
 - 4.2 Mode Diagram 12
- 5. BASIC OPERATION 13
 - 5.1 Basic Key Operation 13
 - 5.2 Display Functions 16

PREPARATION
FOR
MEASURE-
MENT

- 6. USING THE BATTERY 18
 - 6.1 Battery Charging 18
 - 6.2 Installing/Removing the Battery 19
- 7. SETTING UP THE INSTRUMENT 21
 - 7.1 Centering 21
 - 7.2 Levelling 22
- 8. FOCUSING AND TARGET SIGHTING 25
- 9. POWER ON 27

MEASURE-
MENT
-MEASURE-
MENT
MODE -

- 10. ANGLE MEASUREMENT 28
 - 10.1 Measuring the Horizontal Angle between Two Points (Horizontal Angle 0°) 28
 - 10.2 Setting the Horizontal Angle to a Required Value (Horizontal Angle Hold) 29
 - 10.3 Horizontal Angle Repetition 30
 - 10.4 Angle Measurement and Outputting the Data 31
- 11. DISTANCE MEASUREMENT 32
 - 11.1 Distance and Angle Measurement 33
 - 11.2 Recalling the Measured Data 34
 - 11.3 Distance Measurement and Outputting the Data 35
 - 11.4 REM Measurement 36
- 12. COORDINATE MEASUREMENT 38
 - 12.1 Entering Instrument Station Data 38
 - 12.2 Azimuth Angle Setting 41
 - 12.3 3-D Coordinate Measurement 43

CONTENTS

MEASURE-
MENT
-MEASURE-
MENT
MODE -

13. RESECTION MEASUREMENT	45
13.1 Coordinate Resection Measurement	46
13.2 Height Resection Measurement	49
14. SETTING-OUT MEASUREMENT	53
14.1 Distance Setting-out Measurement	54
14.2 Coordinates Setting-out Measurement	57
14.3 REM Setting-out Measurement	60
15. SETTING-OUT LINE	62
15.1 Defining Baseline	62
15.2 Setting-out Line Point	62
15.3 Setting-out Line Line	65
16. SETTING-OUT ARC.	69
16.1 Defining an Arc	69
16.2 Setting-out Arc.	73
17. POINT PROJECTION	75
17.1 Defining Baseline	75
17.2 Point Projection	76
18. OFFSET MEASUREMENT	78
18.1 Single-distance Offset Measurement	78
18.2 Angle Offset Measurement	80
18.3 Two-distance Offset Measurement	82
19. MISSING LINE MEASUREMENT	84
19.1 Measuring the Distance between 2 or more Points	84
19.2 Changing the Starting Point	87
20. SURFACE AREA CALCULATION	88
21. RECORDING DATA - RECORD MENU -	93
21.1 Recording Instrument Station Data	93
21.2 Recording Backsight Point	95
21.3 Recording Angle Measurement Data	97
21.4 Recording Distance Measurement Data	99
21.5 Recording Coordinate Data	100
21.6 Recording Distance and Coordinate Data	101
21.7 Recording Notes	102
21.8 Reviewing JOB Data	103

CONTENTS

MANAGING THE
DATA
-MEMORY
MODE-

22. SELECTING/DELETING A JOB	105
22.1 Selecting a JOB	105
22.2 Deleting a JOB	107
23. REGISTERING/DELETING DATA	109
23.1 Registering/Deleting Known Point Data	109
23.2 Reviewing Known Point Data	112
23.3 Registering/Deleting Codes	113
23.4 Reviewing Codes	114
24. OUTPUTTING JOB DATA	115
25. CHANGING THE SETTINGS	118
25.1 Changing Instrument Options	118
25.2 Allocating Key Functions	124
25.3 Changing Password	128
25.4 Restoring Default Settings	129

ADDITIONAL
DETAILS

TROUBLE-
SHOOTING

26. WARNING AND ERROR MESSAGES	130
27. CHECKS AND ADJUSTMENTS	134
27.1 Plate Level	134
27.2 Circular Level	135
27.3 Tilt Sensor	136
27.4 Collimation	140
27.5 Reticle	141
27.6 Optical plummet	142
27.7 Additive Distance Constant	144

INFORMATION
ABOUT
SET

28. STANDARD EQUIPMENT AND OPTIONAL ACCESSORIES	146
28.1 Standard Equipment	146
28.2 Optional Accessories	148
28.3 Target System	151
28.4 Power Supply System	154
29. SPECIFICATIONS	156
30. EXPLANATION	160
30.1 Manually Indexing the Vertical Circle by Face Left, Face Right Measurement	160
30.2 Atmospheric Correction for High Precision Distance Measurement	
31. REGULATIONS	161

1. PRECAUTIONS FOR SAFE OPERATION

For the safe use of the product and prevention of injury to operators and other persons as well as prevention of property damage, items which should be observed are indicated by an exclamation point within a triangle used with WARNING and CAUTION statements in this operator's manual.

The definitions of the indications are listed below. Be sure you understand them before reading the manual's main text.

Definition of Indication



WARNING

Ignoring this indication and making an operation error could possibly result in death or serious injury to the operator.



CAUTION

Ignoring this indication and making an operation error could possibly result in personal injury or property damage.



This symbol indicates items for which caution (hazard warnings inclusive) is urged. Specific details are printed in or near the symbol.



This symbol indicates items which are prohibited. Specific details are printed in or near the symbol.



This symbol indicates items which must always be performed. Specific details are printed in or near the symbol.

1. PRECAUTIONS FOR SAFE OPERATION

General

Warning



Do not use the unit in areas exposed to high amounts of dust or ash, in areas where there is inadequate ventilation, or near combustible materials. An explosion could occur.



Do not perform disassembly or rebuilding. Fire, electric shock, burns, or hazardous radiation exposure could result.



Never look at the sun through the telescope. Loss of eyesight could result.



Do not look at reflected sunlight from a prism or other reflecting object through the telescope. Loss of eyesight could result.



Direct viewing of the sun using the telescope during sun observation will cause loss of eyesight. Use solar filter (option) for sun observation.

 "28.2 Optional Accessories"



When securing the instrument in the carrying case make sure that all catches, including the side catches, are closed. Failure to do so could result in the instrument falling out while being carried, causing injury.

Caution



Do not use the carrying case as a footstool. The case is slippery and unstable so a person could slip and fall off it.



Do not place the instrument in a case with a damaged catch, belt or handle. The case or instrument could be dropped and cause injury.



Do not wield or throw the plumb bob. A person could be injured if struck.











Secure handle to main unit with locking screws. Failure to properly secure the handle could result in the unit falling off while being carried, causing injury.



Tighten the adjustment tribrach clamp securely. Failure to properly secure the clamp could result in the tribrach falling off while being carried, causing injury.

Power Supply

Warning

-  Do not use voltage other than the specified power supply voltage. Fire or electrical shock could result.
-  Do not use damaged power cords, plugs or loose outlets. Fire or electric shock could result.
-  Do not use power cords other than those designated. Fire could result.
-  Do not place articles such as clothing on the battery charger while charging batteries. Sparks could be induced, leading to fire.
-  Use only the specified battery charger to recharge batteries. Other chargers may be of different voltage rating or polarity, causing sparking which could lead to fire or burns.
-  Do not heat or throw batteries into fire. An explosion could occur, resulting in injury.
-  To prevent shorting of the battery in storage, apply insulating tape or equivalent to the terminals. Otherwise shorting could occur resulting in fire or burns.
-  Do not use batteries or the battery charger if wet. Resultant shorting could lead to fire or burns.
-  Do not connect or disconnect power supply plugs with wet hands. Electric shock could result.





Caution

-  Do not touch liquid leaking from batteries. Harmful chemicals could cause burns or blisters.

1. PRECAUTIONS FOR SAFE OPERATION



Tripod

Caution

-  When mounting the instrument to the tripod, tighten the centering screw securely. Failure to tighten the screw properly could result in the instrument falling off the tripod, causing injury.
-  Tighten securely the leg fixing screws of the tripod on which the instrument is mounted. Failure to tighten the screws could result in the tripod collapsing, causing injury.
-  Do not carry the tripod with the tripod shoes pointed at other persons. A person could be injured if struck by the tripod shoes.
-  Keep hands and feet away from the tripod shoes when fixing the tripod in the ground. A hand or foot stab wound could result.
-  Tighten the leg fixing screws securely before carrying the tripod. Failure to tighten the screws could lead to the tripod legs extending, causing injury.

Wireless Keyboard

Caution

-  Do not perform disassembly or rebuilding. Fire, electric shock or burns could result.
-  Do not use batteries if wet and do not touch batteries with wet hands. Resultant shorting could lead to fire or burns.
-  When changing batteries, follow the procedure described below. If you try to open the battery cover the wrong way or try to force it open, you might injure yourself.

2. PRECAUTIONS

Tribrach Clamp

- When the instrument is shipped, the tribrach clamp is held firmly in place with a locking screw to prevent the instrument from shifting on the levelling base. Before using the instrument the first time, loosen this screw with a screwdriver. And before transporting it, tighten the locking screw to fasten the tribrach clamp in place so that it will not shift on the levelling base.

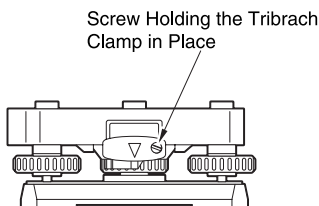

Precautions concerning water and dust resistance

SET conforms to IP66 specifications for waterproofing and dust resistance when the battery cover is closed and connector caps are attached correctly.

- Be sure to close the battery cover and correctly attach the connector caps to protect the SET from moisture and dust particles.
- Make sure that moisture or dust particles do not come in contact with the inside of the battery cover, terminal or connectors. Contact with these parts may cause damage to the instrument.
- Make sure that the inside of the carrying case and the instrument are dry before closing the case. If moisture is trapped inside the case, it may cause the instrument to rust.

Backup data

- Data should be backed up (transferred to an external device etc.) on a regular basis to prevent data loss.

Other precautions

- If the SET is moved from a warm place to an extremely cold place, internal parts may contract, making the keys difficult to operate. This is caused by cold air trapped inside the hermetically sealed casing. If the keys do not depress, open the battery cover to resume normal functionality. To prevent the keys from becoming stiff, remove the connector caps before moving the SET to a cold place.
- Never place the SET directly on the ground. Sand or dust may cause damage to the screw holes or the centering screw on the base plate.
- Do not aim the telescope at the sun. Use the Solar filter to avoid causing internal damage to the instrument when observing the sun.

 "28.2 Optional Accessories"

2. PRECAUTIONS

- Protect the SET from heavy shocks or vibration.
- Never carry the SET on the tripod to another site.
- Turn the power off before removing the battery.
- When placing the SET in its case, first remove its battery and place it in the case in accordance with the layout plan.
- Consult your local dealer before using the instrument under special conditions such as long periods of continuous use or high levels of humidity. In general, special conditions are treated as being outside the scope of the product warranty.

Maintenance

- Always clean the instrument before returning it to the case. The lens requires special care. First, dust it off with the lens brush to remove tiny particles. Then, after providing a little condensation by breathing on the lens, wipe it with a soft clean cloth or lens tissue.
- If the display is dirty, carefully wipe it with a soft, dry cloth. To clean other parts of the instrument or the carrying case, lightly moisten a soft cloth in a mild detergent solution. Wring out excess water until the cloth is slightly damp, then carefully wipe the surface of the unit. Do not use any organic solvents or alkaline cleaning solutions.
- Store the SET in a dry room where the temperature remains fairly constant.
- Check the tripod for loose fit and loose screws.
- If any trouble is found on the rotatable portion, screws or optical parts (e.g. lens), contact your local dealer.
- When the instrument is not used for a long time, check it at least once every 3 months.

"27. CHECKS AND ADJUSTMENTS"

- When removing the SET from the carrying case, never pull it out by force. The empty carrying case should be closed to protect it from moisture.
- Check the SET for proper adjustment periodically to maintain the instrument accuracy.

- The user of this product is expected to follow all operating instructions and make periodic checks of the product's performance.
- The manufacturer, or its representatives, assumes no responsibility for results of faulty or intentional usage or misuse including any direct, indirect, consequential damage, or loss of profits.
- The manufacturer, or its representatives, assumes no responsibility for consequential damage, or loss of profits due to any natural disaster, (earthquake, storms, floods etc.), fire, accident, or an act of a third party and/or usage under unusual conditions.
- The manufacturer, or its representatives, assumes no responsibility for any damage (change of data, loss of data, loss of profits, an interruption of business etc.) caused by use of the product or an unusable product.
- The manufacturer, or its representatives, assumes no responsibility for any damage, and loss of profits caused by usage different to that explained in the operator's manual.
- The manufacturer, or its representatives, assumes no responsibility for damage caused by incorrect operation, or action resulting from connecting to other products.

3. LASER SAFETY INFORMATION

Series 20K is classified as the class1 of Laser Product and Laser Product according to IEC Standard Publication 60825-1 2nd edition: 2007 and United States Government Code of Federal Regulation FDA CDRH 21CFR Part1040.10 and 1040.11 (Complies with FDA performance standards for laser products except for deviations pursuant to Laser Notice No.50, dated June 24, 2007.)

Warning

- Use of controls or adjustments or performance of procedures other than those specified herein may result in hazardous radiation exposure.
- Follow the safety instructions on the labels attached to the instrument as well as in this manual to ensure safe use of this laser product.

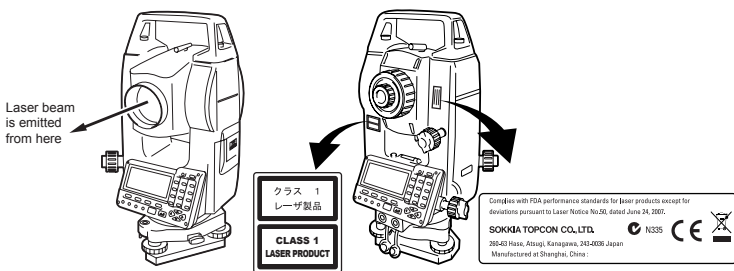

- Never intentionally point the laser beam at another person. The laser beam is injurious to the eyes and skin.
- If an eye injury is caused by exposure to the laser beam, seek immediate medical attention from a licensed ophthalmologist.

Caution

- Perform checks at start of work and periodic checks and adjustments with the laser beam emitted under normal conditions.
- When the instrument is not being used, turn off the power and replace the lens cap.
- When disposing of the instrument, destroy the battery connector so that the laser beam cannot be emitted.

4. SET FUNCTIONS

4.1 Parts of the Instrument

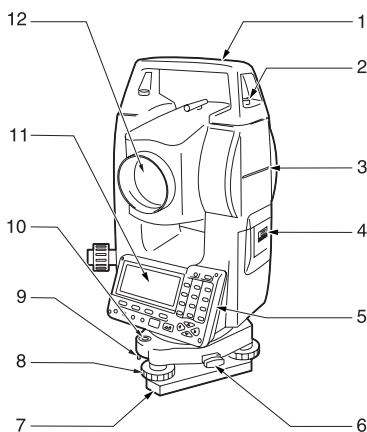

- 1 Handle
- 2 Handle securing screw
- 3 Instrument height mark
- 4 Battery cover
- 5 Operation panel
- 6 Tribrach clamp
- 7 Base plate
- 8 Levelling foot screw
- 9 Circular level adjusting screws
- 10 Circular level
- 11 Display
- 12 Objective lens

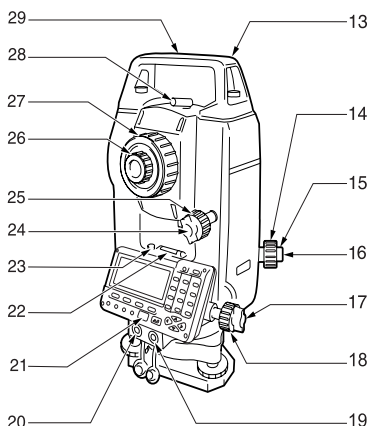

- 13 Tubular compass slot
- 14 Optical plummet focussing ring
- 15 Optical plummet reticle cover
- 16 Optical plummet eyepiece
- 17 Horizontal clamp
- 18 Horizontal fine motion screw
- 19 Data input/output connector (Beside the operation panel on SET620K)
- 20 External power source connector (Not included on SET620K)
- 21 Beam detector for wireless keyboard (Not included on SET620K)
- 22 Plate level
- 23 Plate level adjusting screw
- 24 Vertical clamp
- 25 Vertical fine motion screw
- 26 Telescope eyepiece
- 27 Telescope focussing ring
- 28 Peep sight
- 29 Instrument center mark

4. SET FUNCTIONS



Peep sight

Use peep sight to aim the SET in the direction of the measurement point. Turn the instrument until the triangle in the peep sight is aligned with the target.



Instrument height mark

The height of the SET is 236mm (from tribrach dish to this mark).

"Instrument height" is input when setting instrument station data and is the height from the measuring point (where SET is mounted) to this mark.

Operation panel

"5.1 Basic Key Operation"

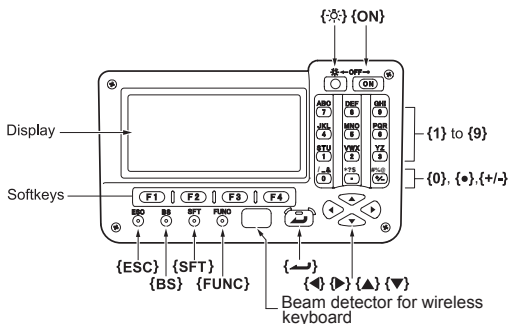

Wireless keyboard (Optional accessory)

☞ "5.1 Basic Key Operation" and "28.2 Optional Accessories"

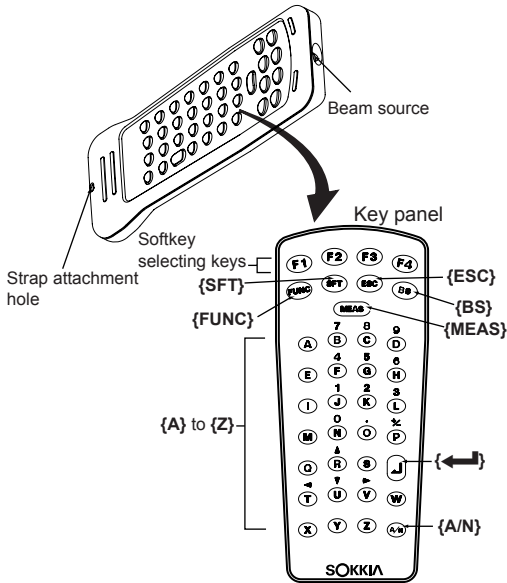

- Wireless keyboard cannot be used on SET620K.

4.2 Mode Diagram

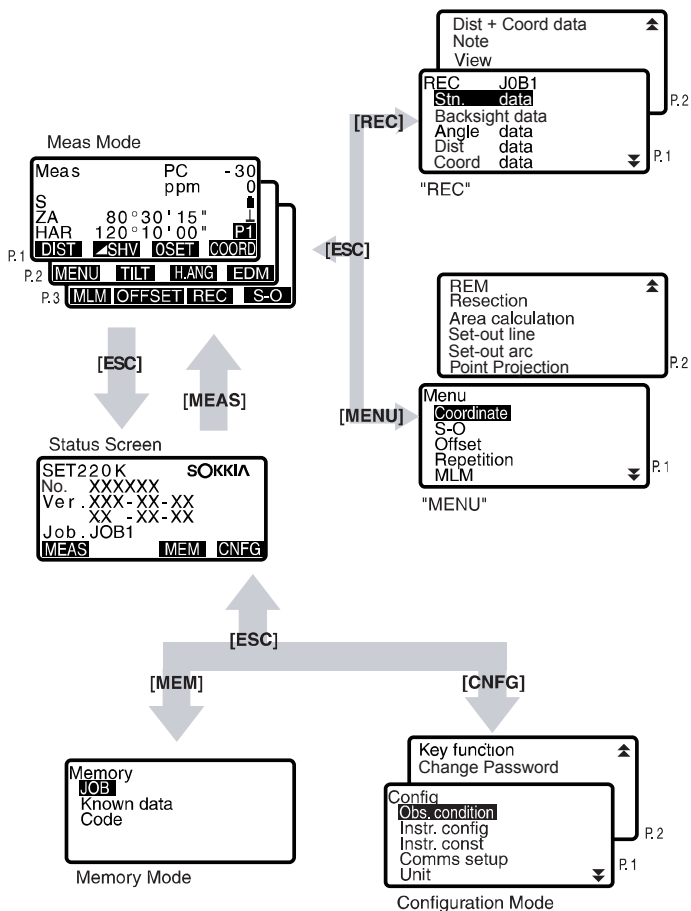

5. BASIC OPERATION

5.1 Basic Key Operation

Learn basic key operations here before you read each measurement procedure.

 Location of operation keys on the panel and Location of operation keys on the wireless keyboard : "4.1 Parts of the Instrument"

- Wireless keyboard (SF14) (Optional accessory) makes key operation easier and speedier.

 Specification of the keyboard: "28.2 Optional Accessories"

● Power ON/OFF

{ON}	Power On
{ON} (while pressing) + 	Power Off

● Lighting up the display and keys



	Switch the screen/key backlight On/Off
--	--

● Softkey operation

Softkeys are displayed on the bottom line of the screen.

{F1} to {F4}	Select the function matching the softkeys
{FUNC}	Toggle between Meas mode screen pages (when more than 4 softkeys are allocated)

● Inputting letters/figures

{SFT}	Switch between numeric and alphabetic characters.
{0} to {9}	During numeric input, input number of the key. During alphabetic input, input the characters displayed above the key in the order they are listed.
{.}	Input a decimal point during numeric input.
{±}	Input plus or minus sign during numeric input.
{  }/ 	Right and left cursor/Select other option.
{ESC}	Cancel the input data.
{BS}	Delete a character on the left.
{ 	Select/accept input word/value.

5. BASIC OPERATION

Example :Entering "JOB M" in the JOB name field

1. Press **{SFT}** to enter the alphabet input mode
Alphabet input mode is indicated by an "A" on the right of the screen.
2. Press **{4}**.
"J" is displayed.
3. Press **{5}** three times.
"O" is displayed.
4. Press **{7}** twice.
"B" is displayed.
5. Press **{▶}** once.
Input a blank space.
6. Press **{5}** once.
"M" is displayed. Press **{←}** to complete inputting.

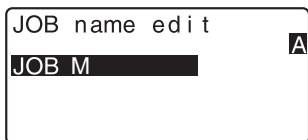

● Selecting options

- {▲}/▼** : Up and down cursor
- {▶}/◀** : Right and left cursor/Select other option
- {←}** : Accept the option

Example: Select a reflector type

1. Press **[EDM]** in page 2 of Meas Mode.
2. Move to "Reflector" using **{▲}/▼**.
3. Display the option you want to select using **{▶}/◀**.
Switches between "Sheet" and "Prism."
4. Press **{←}** or **▼** to move to the next option.
The selection is set and you can set the next item.

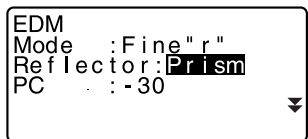

● Switching modes

[CNFG]	From Status mode to Config Mode (Configuration Mode)
[MEAS]	From Status mode to Meas Mode (Measurement Mode)
[MEM]	From Status mode to Memory Mode
{ESC}	Return to the Status mode from each Mode

 "4.2 Mode Diagram"

● Other operation

{ESC}	Return to the previous screen
-------	-------------------------------

5.2 Display Functions

Status screen

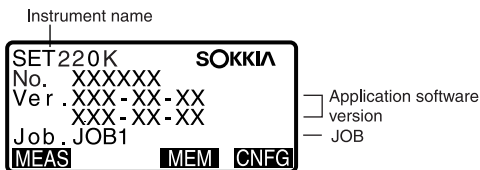

Meas Mode screen

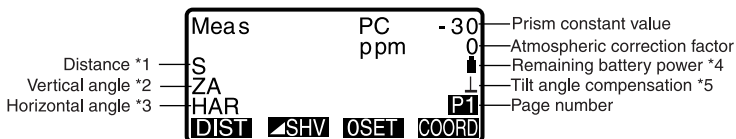

* 1 Distance

☞ Switching distance display status: "25.1 Changing Instrument Options ● Settings in Config Mode"

S : Slope distance

H : Horizontal distance

V : Height difference

* 2 Vertical angle

☞ Switching vertical angle display status: "25.1 Changing Instrument Options ● Settings in Config Mode"

ZA : Zenith angle (Z=0)

VA : Vertical angle (H=0/H=±90)

To switch vertical angle/slope in %, press [ZA/%]

* 3 Horizontal angle

Press [R/L] to switch the display status.

HAR: Horizontal angle right

HAL: Horizontal angle left

* 1,2,3

To switch usual "S, ZA, H" display to "S, H, V", press [▲ SHV].

* 4 Remaining battery power (BDC46B, Temperature=25°C, EDM on)

 : level 3 Full power.

 : level 2 Plenty of power remains.

 : level 1 Half or less power remains.

 : level 0 Little power remains. Charge the battery.

 (This symbol is displayed every 3 seconds): No power remains.
Stop the measurement and charge the battery.

 "6.1 Battery Charging"

* 5 Tilt angle compensation

When this symbol is displayed, the vertical and horizontal angles are automatically compensated for small tilt errors using 2-axis tilt sensor.

 Tilt compensation setting: "25.1 Changing Instrument Options ●
Settings in Config Mode"

6. USING THE BATTERY

6.1 Battery Charging

The battery has not been charged at the factory.



- Do not short circuit. Heat or ignition could result.
- Batteries cannot be charged, even when the charging lamp is flashing, when the temperature is outside the charging temperature range.
- Do not leave the battery in places exposed to high temperatures (more than 35°C). Doing so may reduce the life of the battery.
- Charge the battery once a month to maintain its quality when not in use for long periods.
- Do not charge the battery just after charging is completed. Battery performance may decline.
- Do not use to charge batteries other than those specified.
- If you allow the battery level to get too low, the battery may not be rechargeable or operating time may decline. Keep the battery always charged.
- The charger will become rather hot during use. This is normal.

► PROCEDURE

1. Connect the power cable to the CDC68 charger and plug the charger into the wall outlet.
2. Mount the battery (BDC46B) in the charger (CDC68) matching the groove on the battery with the guides on the charger. When charging starts, the lamp starts blinking.
3. Charging takes less than 2.5 hours.
The lamp lights when charging is finished.
4. Remove the battery and unplug the charger.

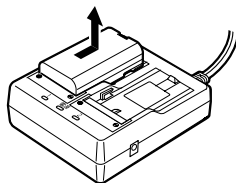
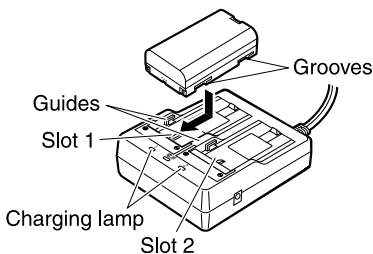

Note

- Slots 1 and 2: The charger starts charging the battery mounted first. If you place two batteries in the charger, the battery in slot 1 is charged first, and then the battery in slot 2. (step 2)
- Charging lamp: The charging lamp is off when the charger is outside the charging temperature range or when the battery is mounted incorrectly. If the lamp is still off after the charger falls within its charging temperature range and the battery is mounted again, contact your local dealer. (steps 2 and 3)

6.2 Installing/Removing the Battery

Mount the charged battery.



- When removing the battery, turn the power off.
- When installing/removing the battery, make sure that moisture or dust particles do not come in contact with the inside of the instrument.

► PROCEDURE

1.

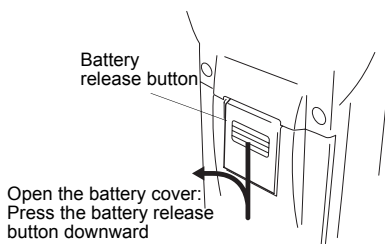

2.

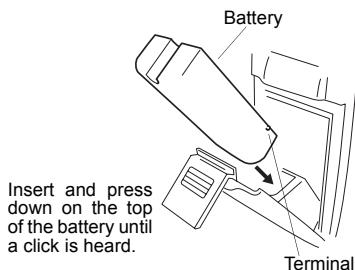

6. USING THE BATTERY

3.

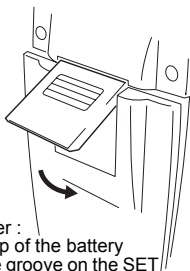

Close the battery cover :
Insert the lip on the top of the battery
release button into the groove on the SET
and press until a click is heard.

Note

- Battery cover

If the battery cover is open during power on, SET notifies you by displaying the screen below and beeping.

When the battery cover is closed, the previous screen is restored.

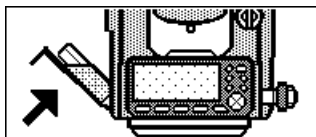

7. SETTING UP THE INSTRUMENT



- Mount the battery in the instrument before performing this operation because the instrument will tilt slightly if the battery is mounted after levelling.

7.1 Centering

► PROCEDURE

1. Make sure the legs are spaced at equal intervals and the head is approximately level.
Set the tripod so that the head is positioned over the surveying point.
Make sure the tripod shoes are firmly fixed in the ground.

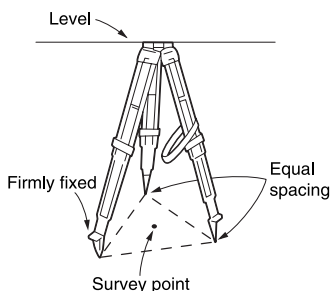

2. Place the instrument on the tripod head.
Supporting it with one hand, tighten the centering screw on the bottom of the unit to make sure it is secured to the tripod.

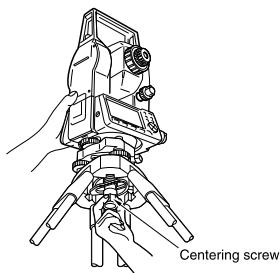

3. Looking through the optical plummet eyepiece, turn the optical plummet eyepiece to focus on the reticle.
Turn the optical plummet focusing ring to focus on the surveying point.

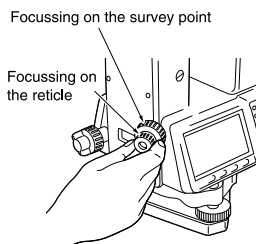

7. SETTING UP THE INSTRUMENT

7.2 Levelling

Instrument can be levelled using the screen.

 "Note" Levelling on the screen"

► PROCEDURE

1. Adjust the levelling foot screws to center the surveying point in the optical plummet reticle.

Center the bubble in the circular level by either shortening the tripod leg closest to the offcenter direction of the bubble or by lengthening the tripod leg farthest from the offcenter direction of the bubble. Adjust one more tripod leg to center the bubble.

Turn the levelling foot screws while checking the circular level until the bubble is centered in the center circle.

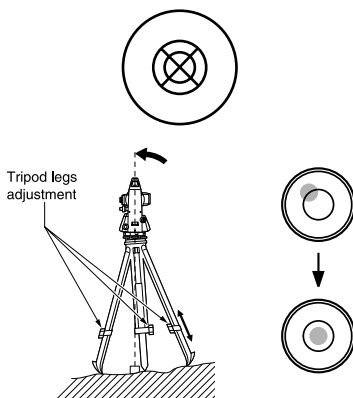

2. Loosen the horizontal clamp to turn the upper part of the instrument until the plate level is parallel to a line between levelling foot screws A and B simultaneously.

Center the air bubble using levelling foot screws A and B. The bubble moves towards a clockwise rotated levelling foot screw.

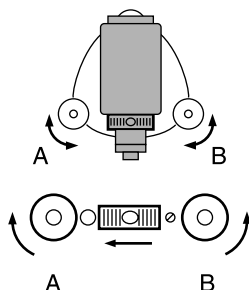

7. SETTING UP THE INSTRUMENT

- Turn the upper part of the instrument through 90° . The plate level is now perpendicular to a line between levelling foot screws A and B. Center the air bubble using levelling foot screw C.

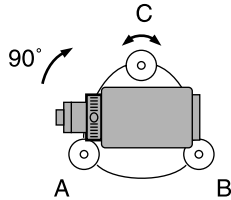

- Turn the upper part of the instrument a further 90° and check to see if the bubble is still in the center of the plate level. If the bubble is off-center, perform the following:
 - Turn levelling foot screws A and B equally in opposite directions to remove half of the bubble displacement.
 - Turn the upper part a further 90° , and use levelling foot screw C to remove half of the displacement in this direction.

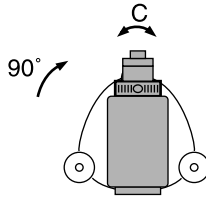

Or adjust the plate level.

 "27.1 Plate Level"

- Turn the instrument and check to see if the air bubble is in the center position in all directions. If it is not, repeat the levelling procedure.
- Loosen the centering screw slightly. Looking through the optical plummet eyepiece, slide the instrument over the tripod head until the surveying point is exactly centered in the reticle. Retighten the centering screw securely.

7. SETTING UP THE INSTRUMENT

7. Check again to make sure the bubble in the plate level is centered.
If not, repeat the procedure starting from step 3.

►PROCEDURE Levelling on the screen

1. Press **{ON}** to power on.
2. Press **[TILT]** in the second page of Meas Mode to display the circular level on the screen.
"●" indicates bubble in circular level. The range of the inside circle is $\pm 4'$ and the range of the outside circle is $\pm 6'$.
Tilt angle values X and Y are also displayed on the screen.

3. Center "●" in the circular level.
 "7.2 Levelling", steps 1 to 2

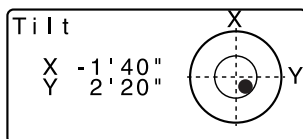

4. Turn the instrument until the telescope is parallel to a line between levelling foot screws A and B, then tighten the horizontal clamp.
5. Set the tilt angle to 0° using foot screws A and B for the X direction and levelling screw C for the Y direction.
6. Press **{ESC}** to return to Meas Mode.

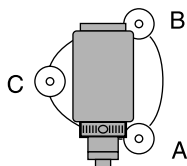

8. FOCUSING AND TARGET SIGHTING



- When sighting the target, strong light shining directly into the objective lens may cause the instrument to malfunction. Protect the objective lens from direct light by attaching the lens hood. Observe to the same point of the reticle when the telescope face is changed.

►PROCEDURE

1. Look through the telescope eyepiece at a bright and featureless background. Turn the eyepiece clockwise, then counterclockwise little by little until just before the reticle image becomes focussed. Using these procedures, frequent reticle refocussing is not necessary since your eye is focussed at infinity.
2. Loosen the vertical and horizontal clamps, then use the peep sight to bring the target into the field of view. Tighten both clamps.
3. Turn the telescope focussing ring to focus on the target. Turn the vertical and horizontal fine motion screws to align the target with the reticle. The last adjustment of each fine motion screw should be in the clockwise direction.

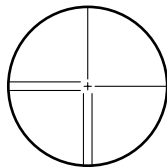

8. FOCUSING AND TARGET SIGHTING

4. Readjust the focus with the focussing ring until there is no parallax between the target image and the reticle.



Eliminating parallax

This is the relative displacement of the target image with respect to the reticle when the observer's head is moved slightly before the eyepiece.

Parallax will introduce reading errors and must be removed before observations are taken. Parallax can be removed by refocussing the reticle.

9. POWER ON

☞ Setting "V manual": "25.1 Changing Instrument Options ● Settings in Config Mode", Setting/changing password: "25.3 Changing Password"

►PROCEDURE

1. Press {ON}.

When the power is switched on, a self-check is run to make sure the instrument is operating normally.

- When password is set, the display appears as at right. Input password and press {←}.



- When "V manual" is set to "Yes", the display appears as at right.

☞ Manually indexing the vertical circle by face left, face right measurements:

"30. EXPLANATION"

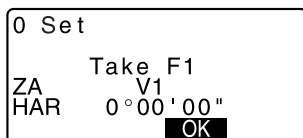

After that, the Meas Mode screen appears.

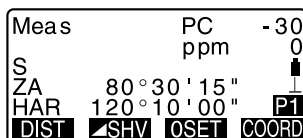

If "Out of range" is displayed, the instrument tilt sensor is indicating that the instrument is out of level. Level the instrument once again and the horizontal and vertical angles will be displayed.

Note

- When "Resume" in "Instr. config" is set to "On", the screen previous to power off is displayed.
☞ "25.1 Changing Instrument Options ● Settings in Config Mode"
- "Tilt crn" in "Obs. condition" should be set to "No" if the display is unsteady due to vibration or strong wind.
☞ "25.1 Changing Instrument Options ● Settings in Config Mode"

10. ANGLE MEASUREMENT

This section explains the procedures for basic angle measurement.

10.1 Measuring the Horizontal Angle between Two Points (Horizontal Angle 0°)

Use the "0SET" function to measure the included angle between two points. The horizontal angle can be set to 0 at any direction.

► PROCEDURE

1. Sight the first target as at right.

1st target

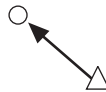

Instrument Station

2. In the first page of the Meas mode screen, press [0SET].

[0SET] will flash, so press [0SET] again.

The horizontal angle at the first target becomes 0°.

Meas	PC	-30
	ppm	0
ZA	89°59'50"	↓
HAR	0°00'00"	P1
DIST	▲SHV	0SET
		COORD

3. Sight the second target.

2nd Target



The displayed horizontal angle (HAR) is the included angle between two points.

Meas	PC	-30
	ppm	0
ZA	89°59'50"	↓
HAR	117°32'20"	P1
DIST	▲SHV	0SET
		COORD

10.2 Setting the Horizontal Angle to a Required Value (Horizontal Angle Hold)

You can reset the horizontal angle to a required value and use this value to find the horizontal angle of a new target.

► PROCEDURE

1. Sight the first target.
2. In the second page of the Meas mode screen, press **[H.ANG]**.
Select "Angle."
3. Enter the angle you wish to set, then press **[OK]**.
The value that is input as the horizontal angle is displayed.
When **[REC]** is pressed, backsight angle can be set in the JOB.
 "21.2 Recording Backsight Point"

```

Set H angle
Take BS
ZA      71° 23' 46"
HAR     347° 23' 46"
HAR:    125.3220
REC     OK
  
```

4. Sight the second target.
The horizontal angle from the second target to the value set as the horizontal angle is displayed.

```

Meas      PC      -30
          ppm
S
ZA      89° 59' 50"
HAR     125° 32' 20"
MENU    TILT    H.ANG    EDM
  
```

Note

- Pressing **[HOLD]** performs the same function as above.
- Press **[HOLD]** to set the displayed horizontal angle. Then, set the angle that is in hold status to the direction you require.
 Allocating **[HOLD]**: "25.2 Allocating Key Functions"

10. ANGLE MEASUREMENT

10.3 Horizontal Angle Repetition

To find the horizontal angle with greater precision, perform repetition measurement.

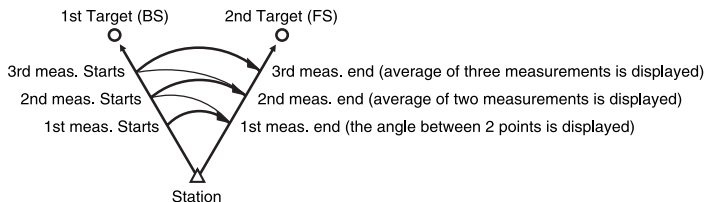

- The maximum number of angle measurements that can be made is 10.

► PROCEDURE

1. Allocate the **[REP]** softkey to the Meas mode screen.

 "25.2 Allocating Key Functions"

2. Press **[REP]**.
The horizontal angle becomes 0°.

3. Sighting the first target, press **[OK]**.

```
Repetition
HARp  0°00'00"
Reps.  0
Ave.   0°00'00"
Take BS
[CE] [OK]
```

4. Sighting the second target, press **[OK]**.

5. Sighting the first target a second time, press **[OK]**.

6. Sighting the second target a second time, press **[OK]**.
The added value of the horizontal angle is displayed on the second line "HARp" and the average value of the horizontal angle is displayed on the fourth line "Ave."

```
Repetition
HARp  110°16'20"
Reps.  2
Ave.   50°38'10"
Take BS
[CE] [OK]
```

- Return to the previous measurement of the first target and redo it: **[CE]**.
(Effective when the display shows "Take BS")
7. When continuing the repetition measurement, repeat steps 4 to 5.
 8. When the repetition measurement is completed, press **{ESC}**.

Note

- It is also possible to perform repetition measurement by pressing **[MENU]** on page 2 of the Meas mode screen to enter <Menu>, then selecting "Repetition" without allocating the function key.

10.4 Angle Measurement and Outputting the Data

The following explains angle measurement and the features used to output measurement data to a computer or peripheral equipment.



Communication cables: "28.2 Optional Accessories"

Output format and command operations: "Interfacing with the SOKKIA SDR Electronic Field Book" and "Command Explanations" manuals.

► PROCEDURE

1. Connect SET and host computer.
2. Allocate the **[D-OUT]** softkey to the Meas mode screen.
 "25.2 Allocating Key Functions"
3. Sight the target point.
4. Press **[D-OUT]** and select "Angle Data."
Output measurement data to peripheral equipment.

11. DISTANCE MEASUREMENT

Perform the following settings as preparation for distance measurement.

- Distance measurement mode
- Target type
- Prism constant correction value
- Atmospheric correction factor
- EDM Standby
- EDM ALC

 "25.1 Changing Instrument Options ● EDM Settings/● Settings in Config Mode"

- Check to make sure that sufficient reflected light is returned by the reflective prism sighted by the telescope. Checking the returned signal is particularly useful when performing long distance measurements.



- When the light intensity is sufficient even though the center of the reflective prism and the reticle are slightly misaligned (short distance etc.), "*" will be displayed in some cases, but in fact, accurate measurement is impossible. Therefore make sure that the target center is sighted correctly.
- Scintillation may affect the accuracy of distance of measurement results. Should this occur, repeat measurement several times and use the averaged value of the obtained results.

►PROCEDURE Returned Signal Checking

1. Allocate the **[AIM]** softkey to the Meas mode screen.

 "25.2 Allocating Key Functions"

2. Accurately sight the target.

3. Press **[AIM]**.

<Aiming> is displayed.

The intensity of the light of the returned signal is displayed by a gauge.

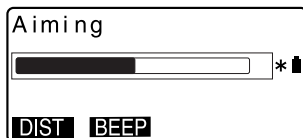

- The more  displayed, the greater the quantity of reflected light.

- If "" is displayed; only enough light for the measurement is returned.
- When "" is not displayed, accurately resight the target.
- Press **[BEEP]** to make a buzzer sound when measurement is possible. Press **[OFF]** to shut off the buzzer.
- Press **[DIST]** to shift distance measurement.
- Press **{ESC}** to finish signal checking and return to Meas Mode.



- When ██████████ is displayed persistently, contact your local dealer.
- If no key operations are performed for two minutes, the display automatically returns to the Meas mode screen.

11.1 Distance and Angle Measurement

An angle can be measured at the same time as the distance.

► PROCEDURE

1. Sight the target.
2. In the first page of Meas Mode, press **[DIST]** to start distance measurement.

When measurement starts, EDM information (distance mode, prism constant correction value, atmospheric correction factor) is represented by a flashing light.

Meas	PC	-30
	ppm	0
S		
ZA	80°30'15"	
HAR	120°10'00"	P1
[DIST]	[SHV]	[OSET] [COORD]

Dist	PC	-30
Fine " r "	ppm	0
[STOP]		

11. DISTANCE MEASUREMENT

A short beep sounds, and the measured distance data (S), vertical angle (ZA), and horizontal angle (HAR) are displayed.

Meas	PC	-30
	ppm	0
S	525.450m	↓
ZA	80°30'10"	↓
HAR	120°10'00"	↓
STOP		

3. Press **[STOP]** to quit distance measurement.

- Each time **[▲SHV]** is pressed, S (Slope distance), H (Horizontal distance) and V (Height difference) are displayed alternately.

Meas	PC	-30
	ppm	0
S	525.450m	↓
H	518.248m	↓
V	86.699m	P1
DIST	▲SHV	0SET
COORD		

Note

- If the single measurement mode is selected, measurement automatically stops after a single measurement.
- During fine average measurement, the distance data is displayed as S-1, S-2, ... to S-9. When the designated number of measurements has been completed, the average value of the distance is displayed in the [S-A] line.
- The distance and angle that are most recently measured remain stored in the memory until the power is off and can be displayed at any time.
 "11.2 Recalling the Measured Data"

11.2 Recalling the Measured Data

The distance and angle that are most recently measured remain stored in the memory until the power is off and can be displayed at any time.

The distance measurement value, vertical angle, horizontal angle, and the coordinates can be displayed. Distance measurement values converted into the horizontal distance, elevation difference, and the slope distance can also be displayed.

► PROCEDURE

1. Allocate the **[RCL]** softkey to the Meas mode screen.
 "25.2 Allocating Key Functions"

2. Press **[RCL]**.
The stored data that is most recently measured is displayed.

S	525.450m
ZA	80°30'10"
HAR	120°10'10"
N	-128.045
E	-226.237
Z	30.223

- If you have pressed **[SHV]** beforehand, the distance values are converted into the horizontal distance, elevation difference, and the slope distance and recalled.

3. Press **{ESC}** to return to Meas mode.

11.3 Distance Measurement and Outputting the Data

The following explains distance measurement and the features used to output measurement data to a computer or peripheral equipment.

 Communication cables: "28.2 Optional Accessories"

Output format and command operations: "Interfacing with the SOKKIA SDR Electronic Field Book" and "Command Explanations" manuals.

► PROCEDURE

1. Connect SET and host computer.
2. Allocate the **[D-OUT]** softkey to the Meas mode screen.
 "25.2 Allocating Key Functions"
3. Sight the target point.
4. Press **[D-OUT]**, and select "Dist data" to measure the distance and output the data to peripheral equipment.
5. Press **[STOP]** to stop the data outputting and return to Meas Mode.

11. DISTANCE MEASUREMENT

11.4 REM Measurement

An REM measurement is a function used to measure the height to a point where a target cannot be directly installed such as power lines, overhead cables and bridges, etc.

The height of the object is calculated using the following formula.

$$H_t = h_1 + h_2$$

$$h_2 = S \sin \theta_{z1} \times \cot \theta_{z2} - S \cos \theta_{z1}$$

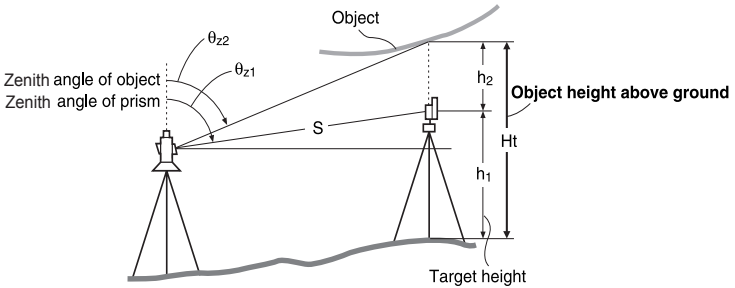

► PROCEDURE

1. Allocate the **[REM]** softkey to the Meas mode screen.

 "25.2 Allocating Key Functions"

2. Set the target directly under or directly over the object and measure the target height with a tape measure etc.

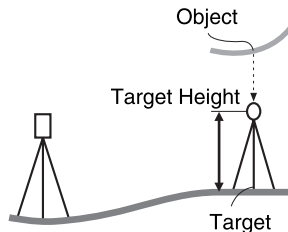

3. After inputting the target height, accurately sight the target.

 "Note"

Press **[DIST]** in page 1 of Meas Mode to carry out measurement.

The measured distance data (S), vertical angle (ZA), and horizontal angle (HAR) are displayed.

Press **[STOP]** to stop the measurement.

4. Sight the object, then press **[REM]**. The REM measurement is started and the height from the ground to the object is displayed in "Ht.".

REM		
Ht .	6.255m	
S	13.120m	█
ZA	89°59'50"	
HAR	117°32'20"	
		STOP

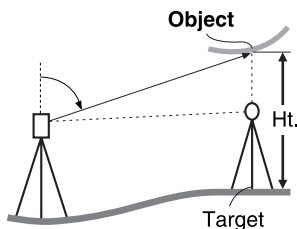

5. Press **[STOP]** to terminate the measurement operation.

- To re-observe the target, sight the target, then press **[OBS]**.

REM		
Ht .	6.255m	
S	13.120m	█
ZA	89°59'50"	
HAR	117°32'20"	
	REM	OBS

6. Press **{ESC}** to finish measurement and return to the Meas mode screen.

Note

- It is also possible to perform REM measurement by pressing **[MENU]** on page 2 of the Meas mode screen and selecting "REM" without allocating the function key.
 - Inputting target height (Step 3): Press **[HT]** to set target height. It can be set also in "Stn. data" of coordinate measurement.
- "12.1 Entering Instrument Station Data"

12. COORDINATE MEASUREMENT

By performing coordinate measurements it is possible to find the 3-dimensional coordinates of the target based on station point coordinates, instrument height, target height, and azimuth angles of the backsight station which are entered in advance.

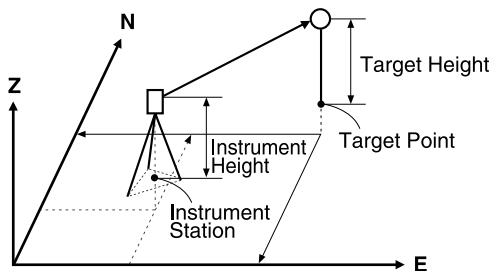

- EDM setting can be done in coordinate measurement menu.
☞ Setting items: "25.1 Changing Instrument Options ● EDM settings"

12.1 Entering Instrument Station Data

Before coordinate measurement, enter instrument station coordinates, the instrument height, and target height.

► PROCEDURE

1. First measure the target height and instrument height with a tape measure, etc.
2. Press **[COORD]** in the first page of the Meas mode screen to display <Coord.>

3. Select "Stn. Orientation," then "Stn. Coordinate."
Input the instrument station coordinates, instrument height and target height.

N0:	0.000
E0:	0.000
Z0:	0.000
Inst.h	1.400m
Tgt.h	1.200m
READ	REC OK

N0:	370.000
E0:	10.000
Z0:	100.000
Inst.h	1.400m
Tgt.h	1.200m
REC	OK

- When you wish to read in the registered coordinate data, press **[READ]**.

 "PROCEDURE Reading in Registered Coordinate Data"

4. Press **[OK]** to set the input values.
<Coord> is displayed again.

- When **[REC]** is pressed, instrument station data is saved.

 "21. RECORDING DATA - RECORD MENU -"

12. COORDINATE MEASUREMENT

►PROCEDURE Reading in Registered Coordinate Data

Known point data, coordinate data and instrument station data in the current JOB and Coordinate Search JOB can be read in.

Confirm that the correct JOB containing the coordinates you want to read in is already selected in Coordinate Search JOB in Memory Mode.

 "23.1 Registering/Deleting Known Point Data", "22.1 Selecting a JOB"

1. Press **[READ]** when setting Instrument Station.
The list of registered coordinates is displayed.
Pt. : Known point data saved in the current JOB or in the Coordinate Search JOB.
Crd./ Stn : Coordinate data saved in the current JOB or in the Coordinate Search JOB.

Pt.	11111111	▲
Pt.	1	
Crd.	2	
Stn	12345679	
Stn	1234	▼
[↑↓...P]	[TOP]	[LAST] [SRCH]

2. Align the cursor with the required point number and press **[←]**.
The point number that was read in and its coordinate is displayed.

N0:	9.876
E0:	5.432
Pt.	PNT-001
Inst.h	0.000 m
Tgt.h	0.000 m
[REC]	[OK]

- **[↑↓...P]** = Use **{▲}**/**{▼}** to move from page to page.
[↑↓...P]= Use **{▲}**/**{▼}** to select individual point.
- Press **[TOP]** to move to the first point number on the first page.
- Press **[LAST]** to move to the last point number on the last page.
- Press **[SRCH]** to move to the "Coordinate Data Search Screen." Input the point number you want to search in "Pt. no." The search may take time if many data are registered.

- Press **[OK]**.
<Instrument Station Data Setting>
is restored.

Note

- The point number that was read in is displayed until the current JOB is changed.
- When **[SRCH]** is pressed, SET searches data in the current JOB first, then in the Coordinate Search JOB.
- If more than two points with the same point name exist in the current JOB, SET finds the newer data only.

12.2 Azimuth Angle Setting

Set the azimuth of the backsight station by inputting the angle or by calculating from coordinates.

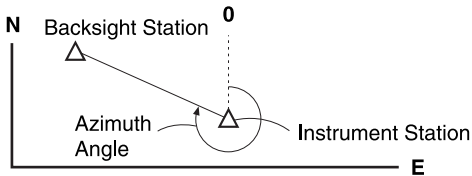

► PROCEDURE

- Select "Stn.Orientation", then "Backsight" in <Coord.>.
- Select "Angle". Angle measurement values are displayed in real time.
- Input azimuth angle.

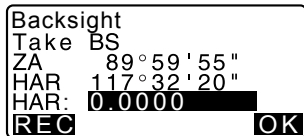

12. COORDINATE MEASUREMENT

- Press **[OK]** in the screen of step 3 to set the backsight station.
<Coord> is restored.

- When storing the azimuth angle in the current JOB, press **[REC]**.

☞ "21.2 Recording Backsight Point PROCEDURE Inputting azimuth angle"

►PROCEDURE Calculating azimuth angle by coordinates

- Select "Strn. Orientation", then "Backsight" in <Coord.>.
- Select "Coord".
- Input the backsight station coordinates and press **[OK]**.
Angle measurement values are displayed in real time. Calculated Azimuth angle is also displayed.

```
Backsight
Angle
Coord
```

```
Backsight
NBS : 1.000
EBS : 1.000
ZBS : <Null>
READ OK
```

```
Backsight
Take BS
ZA 90°12'34"
HAR 123°12'34"
Azimuth 45°00'00"
REC NO YES
```

- When you wish to read in and set coordinate data from memory, press **[READ]**.

☞ "12.1 Entering Instrument Station Data PROCEDURE Reading in Registered Coordinate Data"

4. Press **[YES]** in the screen of step 3 to set azimuth angle.

- When storing the azimuth angle in the current JOB, press **[REC]**.

 "21.2 Recording Backsight Point PROCEDURE Inputting azimuth angle"

12.3 3-D Coordinate Measurement

The coordinate values of the target can be found by measuring the target based on the settings of the instrument station and backsight station.

The coordinate values of the target are calculated using the following formulae.

$$N1 \text{ Coordinate} = N0 + S \times \sin Z \times \cos Az$$

$$E1 \text{ Coordinate} = E0 + S \times \sin Z \times \sin Az$$

$$Z1 \text{ Coordinate} = Z0 + S \times \cos Z + ih - fh$$

- | | | |
|--------------------------------|---------------------|-----------------------|
| N0: Station point N coordinate | S: Slope distance | ih: Instrument height |
| E0: Station point E coordinate | Z: Zenith angle | fh: Target height |
| Z0: Station point Z coordinate | Az: Direction angle | |



Z (zenith angle) is calculated as $360^\circ - Z$ when the telescope is in the face left position if either the horizontal angle has been set to 0 by pressing **[0SET]** or the required horizontal angle has been set by pressing **[H.ANG]**.

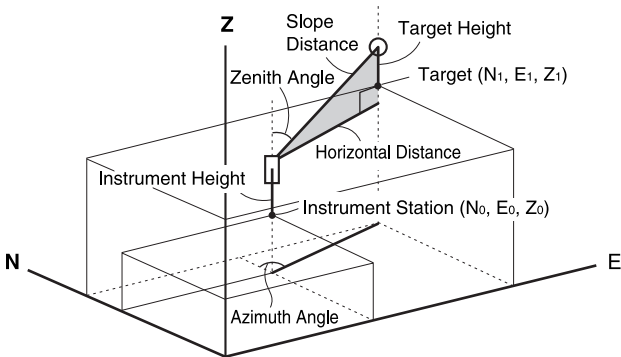

12. COORDINATE MEASUREMENT

- If not measured or the space is left blank "Null" will be displayed.
If station point Z coordinate is set to "Null" the observation result for the Z coordinate is automatically set to "Null".

►PROCEDURE

1. Sight the target at the target point.

2. In <Coord>, select "Observation" to start measurement. The coordinate value of the target is displayed.

Press **[STOP]** to quit measurement.



```
Coord.  
Stn. Orientation  
Observation  
EDM
```

- By pressing **[HT]**, the instrument station data can be reset. When the target height of the next target is different, reenter the target height before beginning the observation.

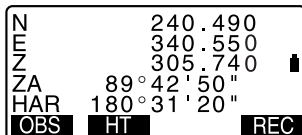

```
N          240.490  
E          340.550  
Z          305.740  
ZA        89° 42' 50"  
HAR       180° 31' 20"  
OBS      HT      REC
```

- **[REC]**: records measurement results

 Recording method:
"21. RECORDING DATA -
RECORD MENU -"

3. Sight the next target and press **[OBS]** to begin measurement. Continue until all targets have been measured.

4. When coordinate measurement is completed, press **[ESC]** to return to <Coord>.

13. RESECTION MEASUREMENT

Resection is used to determine the coordinates of an instrument station by performing multiple measurements of points whose coordinate values are known. Registered coordinate data can be recalled and set as known point data. Residual of each point can be checked, if necessary.

Entry

Output

Coordinates of known point : (X_i, Y_i, Z_i) Station point coordinates : (X_0, Y_0, Z_0)

Observed horizontal angle : H_i

Observed vertical angle : V_i

Observed distance : D_i

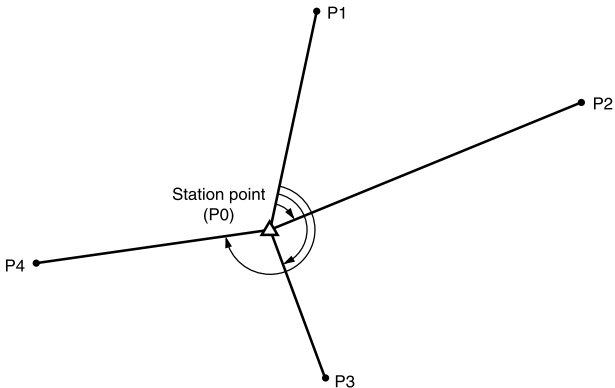

- All the N, E, Z or only Z data of an instrument station is calculated by measuring the known points.
- Coordinate resection measurement overwrites the N, E and Z data of the instrument station, but height resection does not overwrite N and E. Always perform resection measurement in the sequence described in "13.1 Coordinate Resection Measurement" and "13.2 Height Resection Measurement".
- Input known coordinate data and calculated instrument station data can be recorded in the current JOB.

 "22. SELECTING/DELETING A JOB"

13. RESECTION MEASUREMENT

13.1 Coordinate Resection Measurement

N, E, Z of an instrument station is determined by the measurement.

- Between 2 and 10 known points can be measured by distance measurement, and between 3 and 10 known points by angle measurement.

►PROCEDURE

1. Allocate the **[RESEC]** softkey to the Meas mode screen.
☞ "25.2 Allocating Key Functions"
2. Press **[RESEC]** to begin resection measurement.

3. Select "NEZ" and input the known point.
After setting the coordinates for the first known point press **[NEXT]** to move to the second point.
When all required known points have been set, press **[MEAS]**.

	2nd Pt.
Np :	100.000
Ep :	100.000
Zp :	50.000
Tgt.h	1.400m
READ	REC NEXT MEAS

- When **[READ]** is pressed, registered coordinates can be recalled and used.

☞ "12.1 Entering Instrument Station Data PROCEDURE Reading in Registered Coordinate Data"

- Press **[←]** to return to the previous known point.
4. Sight the first known point and press **[DIST]** to begin measurement.
The measurement results are displayed on the screen.

Resection	1st Pt.
N	100.000
E	100.000
Z	50.000
DIST	ANGLE

13. RESECTION MEASUREMENT

- When **[ANGLE]** has been selected, the distance cannot be displayed.

- Press **[YES]** to use the measurement results of the first known point.

Resection	1st Pt.
S	525.450m
ZA	80°30'15"
HAR	120°10'00"
Tgt.h	1.400m
	NO YES

- You can also input target height here.

- Repeat procedures 4 to 5 in the same way from the second point. When the minimum quantity of observation data required for the calculation is present, **[CALC]** is displayed.

- Press **[CALC]** or **[YES]** to automatically start calculations after observations of all known points are completed. Instrument station coordinate and standard deviation, which describes the measurement accuracy, are displayed.

Resection	3rd Pt.
S	125.450m
ZA	40°30'15"
HAR	20°10'00"
Tgt.h	1.200m
CALC	NO YES

- Press **[RESULT]** to check the result. If there are no problems with the result, press **{ESC}** and go to step 11.

N	100.001
E	100.000
Z	9.999
σ N	0.0014m
σ E	0.0007m
RESULT	REC OK

- [REC]**: records measurement results

 Recording method:
"21. RECORDING DATA -
RECORD MENU -"

- Press **[ADD]** when there is a known point that has not been measured or when a new known point is added.

	σ N	σ E
1st	-0.001	0.001
* 2nd	0.005	0.010
3rd	-0.001	0.001
4th	-0.003	-0.002
BAD	RE_CALC	RE_OBS ADD

13. RESECTION MEASUREMENT

9. If there are problems with the results of a point, align the cursor with that point and press **[BAD]**. "*" is displayed on the left of the point. Repeat for all results that include problems.

10. Press **[RE CALC]** to perform calculation again without the point designated in step 9. The result is displayed.

If there are no problems with the result, go to step 11.

If problems with the result occur again, perform the resection measurement from step 4.

- Press **[RE OBS]** to measure the point designated in step 9. If no points are designated in step 9, all the points or only the final point can be observed again.



Resection
Start point
Last point

11. Press **[OK]** in the screen of step 8 to finish resection measurement. The instrument station coordinate is set.

Press **[YES]** when you want to set the azimuth angle of the first known point as the backsight point.

- Press **[NO]** to return to Meas Mode without setting the azimuth angle.

Note

- It is also possible to perform resection measurement by pressing **[MENU]** on page 2 of the Meas mode screen, then selecting "Resection" without allocating the function key.
- Even if "inch" is selected in Config mode, standard deviation is displayed in "feet" or "US feet" depending on the feet unit selected.

13.2 Height Resection Measurement

Only Z (height) of an instrument station is determined by the measurement.

- Known points must be measured by distance measurement only.
- Between 1 and 10 known points can be measured.

►PROCEDURE

1. Press **[RESEC]** to begin resection measurement.

2. Select "Elevation" and input the known point. After setting the elevation for the first known point, press **[NEXT]** to move to the second point.

When all required known points have been set, press **[MEAS]**.

- Press **{ESC}** to return to the previous known point.

1st Pt.	
Zp:	11.891
Tgt.h	0.100m
READ	REC NEXT MEAS

Resection 1st Pt.	
Z	11.891
OBS	

3. Sight the first known point and press **[OBS]** to begin measurement.
The measurement results are displayed on the screen.
4. Press **[YES]** to use the measurement results of the first known point.
5. If measuring two or more known points, repeat procedures 3 to 4 in the same way from the second point.
When the minimum quantity of observation data required for the calculation is present, **[CALC]** is displayed.

13. RESECTION MEASUREMENT

6. Press **[CALC]** or **[YES]** to automatically start calculations after observations of all known points are completed. Instrument station elevation and standard deviation, which describes the measurement accuracy, are displayed.

Z 10.000
 σZ 0.0022m
RESULT **REC** **OK**

7. Press **[RESULT]** to check the result.
If there are no problems in the result, press **{ESC}** and go to step 10.

σZ
1st -0.003
2nd -0.003
3rd 0.000
4th 0.002
BAD **RE_CALC** **RE_OBS** **ADD**

8. If there are problems with the results of a point, align the cursor with that point and press **[BAD]**. "*" is displayed on the left of the point.
9. Press **[RE CALC]** to perform calculation again without the point designated in step 8. The result is displayed.
If there are no problems with the result, go to step 10.
If problems with the result occur again, perform the resection measurement from step 3.
10. Press **[OK]** to finish resection measurement. Only Z (elevation) of the instrument station coordinate is set. N and E values are not overwritten.



Resection calculation process

The NE coordinates are found using angle and distance observation equations, and the instrument station coordinates are found using the method of least squares. The Z coordinate is found by treating the average value as the instrument station coordinates.

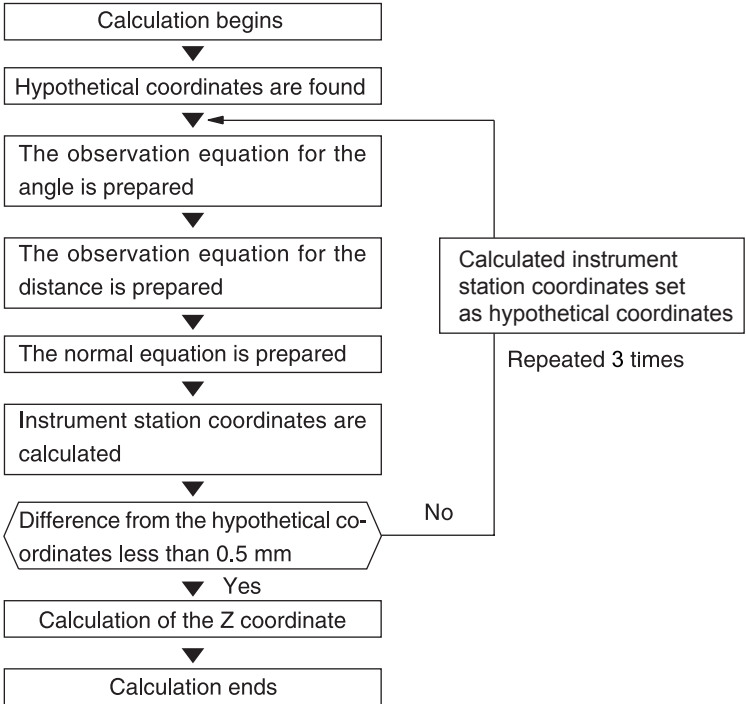

13. RESECTION MEASUREMENT



Precaution when performing resection

In some cases it is impossible to calculate the coordinates of an unknown point (instrument station) if the unknown point and three or more known points are arranged on the edge of a single circle.

An arrangement such as that shown below is desirable.

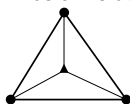

\triangle ▲ : Unknown point

○● : Known point

It is sometimes impossible to perform a correct calculation in a case such as the one below.

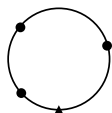

When they are on the edge of a single circle, take one of the following measures.

- (1) Move the instrument station as close as possible to the center of the triangle.

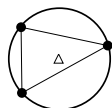

- (2) Observe one more known point which is not on the circle.

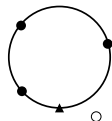

- (3) Perform a distance measurement on at least one of the three points.

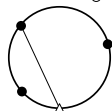

- In some cases it is impossible to calculate the coordinates of the instrument station if the included angle between the known points is too small. It is difficult to imagine that the longer the distance between the instrument station and the known points, the narrower the included angle between the known points. Be careful because the points can easily be aligned on the edge of a single circle.

14. SETTING-OUT MEASUREMENT

Setting-out measurement is used to set out the required point.

The difference between the previously input data to the instrument (the setting-out data) and the measured value can be displayed by measuring the horizontal angle, distance or coordinates of the sighted point.

The horizontal angle difference and distance difference are calculated and displayed using the following formulae.

Horizontal angle difference

dHA = Horizontal angle of setting-out data - measured horizontal angle

Distance difference

Distance Displayed item

Sdist: S-O S =measured slope distance - slope distance of setting-out data

Hdist: S-O H =measured horizontal distance - horizontal distance of setting-out data

Vdist: S-O V =measured height difference - height difference of setting-out data

- Setting out data can be input in various modes: coordinates, horizontal distance, slope distance, height difference and REM measurement.
- In slope distance, horizontal distance, height difference, and coordinate mode, registered coordinates can be recalled and used as setting-out coordinates. In slope distance, horizontal distance and height difference, S/H/V distances are calculated from the read in setting-out coordinate, instrument station data, instrument height, and target height.
- EDM settings can be set in the Setting-out measurement menu.
- If not measured or the space is left blank "Null" will be displayed.
- If distance or angle of setting-out data is set to "Null" the Distance difference is automatically set to "Null".

14. SETTING-OUT MEASUREMENT

14.1 Coordinates Setting-out Measurement

After setting the coordinates for the point to be set out, the SET calculates the setting-out horizontal angle and horizontal distance. By selecting the horizontal angle and then the horizontal distance setting-out functions, the required coordinate location can be set out.

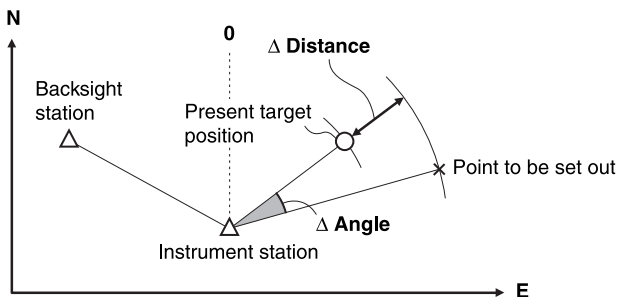

- To find the Z coordinate, attach the target to a pole etc. with the same target height.

► PROCEDURE

1. Press **[S-O]** on the third page of the Meas mode screen to display <S-O>.
2. Enter the instrument station data.
☞ "12.1 Entering Instrument Station Data PROCEDURE Reading in Registered Coordinate Data".
3. Set the azimuth angle of the backsight point.
☞ "12.2 Azimuth Angle Setting" steps 2 to 6
4. Select "S-O data" and press **[▲ S-O]** until <S-O Coord> is displayed.

5. Enter the coordinates of the setting-out point.

- When **[READ]** is pressed, registered coordinates can be recalled and used as setting-out coordinates.

S-O Coord	
Np:	100.000
Ep:	100.000
Zp:	50.000
Tgt. h	1.400m
READ	▲S-O OK

 "12.1 Entering Instrument Station Data PROCEDURE Reading in Registered Coordinate Data"

- When **▲S-O** is pressed, input coordinates are calculated and displayed in "H dist" and "H ang"

S-O H	
H dist:	3.300m
H ang:	40.0000
READ	▲S-O OK P1

6. Press **[OK]** to set the setting-out data.
7. Rotate the top of the instrument until "dHA" is 0° and place the target on the sight line.

8. Press **[OBS]** to begin setting-out measurement. The target and the distance of the point to be set out is displayed (S-OΔH).

S-OΔH	0.820m
dHA	0°09'40"
H	2.480m
ZA	84°41'37"
HAR	191°22'57"
OBS	▲S-O ← → REC

S-OΔH	0.820m
dHA	0°09'40"
H	2.480m
ZA	75°20'30"
HAR	39°05'20"
STOP	

9. Move the prism forward and backward until the setting-out distance is 0m. If S-OΔH is "+", move the prism toward yourself, if it is "-", move the prism away from yourself.

14. SETTING-OUT MEASUREMENT

- By pressing [\leftarrow \rightarrow], an arrow pointing to the left or right displays which direction the target should be moved.

\leftarrow : Move the prism to left.

\rightarrow : Move the prism to right.

\downarrow : Move the prism forward.

\uparrow : Move the prism away.

\blacktriangle : Move the prism upward.

\blacktriangledown : Move the prism downward.

When the target is within measurement range, all four arrows are displayed.

10. Press **{ESC}** to return to <S-O>.

- When **[READ]** was used in step 5, the list of registered coordinates is restored. Continue setting-out measurement.
- **[REC]**: records measurement results

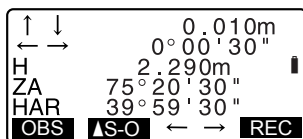

11.  Recording method:
"21. RECORDING DATA -
RECORD MENU -"

14.2 Distance Setting-out Measurement

The point to be found based on the horizontal angle from the reference direction and the distance from the instrument station.

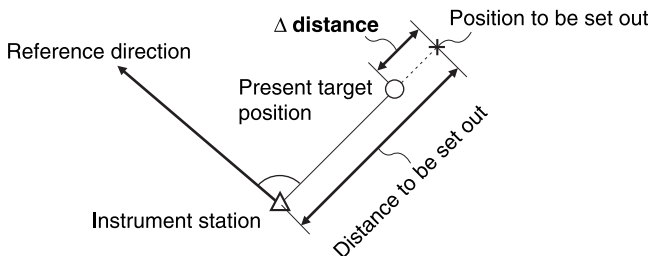

► PROCEDURE

1. Press **[S-O]** in the third page of the Meas mode screen to display <S-O>.
2. Enter the instrument station data.
 "12.1 Entering Instrument Station Data PROCEDURE Reading in Registered Coordinate Data".
3. Set the azimuth angle of the backsight point.
 "12.2 Azimuth Angle Setting" steps 2 to 6.
4. Select "S-O data."

S-O
Stn. Orientation
S-O data
Observation
EDM

14. SETTING-OUT MEASUREMENT

5. Press **[▲S-O]** until <S-O H> is displayed.

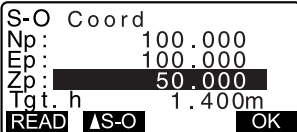

S-O Coord
Np: 100.000
Ep: 100.000
Zp: 50.000
Tgt. h 1.400m
[READ] [▲S-O] [OK]

6. Each time **[▲S-O]** is pressed: S-O Coord (coordinates), S-O H (horizontal distance), S-O S (slope distance), S-O V (height difference), S-O Ht. (REM measurement).

 "14.1 Coordinates Setting-out Measurement", "14.3 REM Setting-out Measurement"

- When **[READ]** is pressed, registered coordinates can be recalled and used. Distance and angle are calculated using the coordinate value.

 "12.1 Entering Instrument Station Data PROCEDURE Reading in Registered Coordinate Data"

7. Set the following items.

- (1) Sdist/Hdist/Vdist: distance from the instrument station to the position to be set out.
- (2) H ang: included angle between the direction of the reference and the point to be set out.

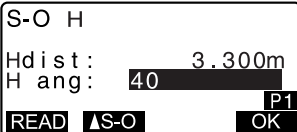

S-O H
Hdist: 3.300m
H ang: 40
[READ] [▲S-O] [OK] P1

- Pressing **[COORD]** in the second page allows you to enter the coordinates of the point to be set out.



S-O H
Hdist: 3.300m
H ang: 40° 00' 00"
[COORD] P2

8. Press **[OK]** to set the input values.

9. Rotate the top of the instrument until "dHA" is 0° and place the target on the sight line.
10. Press **[OBS]** to start distance measurement. The target and the distance of the point to be set out is displayed (S-O Δ H).
11. Move the prism to find the point to be set out.
12. Press **{ESC}** to return to <S-O>.

S-O Δ H	0.820m	
dHA	$0^\circ 09' 40''$	
H	2.480m	
ZA	$75^\circ 20' 30''$	
HAR	$39^\circ 05' 20''$	
OBS	▲S-O	← → REC

- When **[READ]** was used in step 5, the list of registered coordinates is restored. Continue setting-out measurement.
- **[REC]**: records measurement results

 Recording method:
 "21. RECORDING DATA -
 RECORD MENU -"

14. SETTING-OUT MEASUREMENT

14.3 REM Setting-out Measurement

To find a point where a target cannot be directly installed, perform REM setting-out measurement.

 "11.4 REM Measurement"

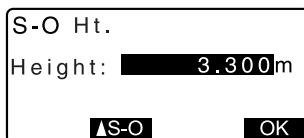

►PROCEDURE

1. Install a target directly below or directly above the point to be found, then use a measuring tape etc. to measure the target height (height from the surveying point to the target).
2. Press **[S-O]** in the Meas mode screen to display <S-O>.
3. Enter the instrument station data.
 "12.1 Entering Instrument Station Data PROCEDURE Reading in Registered Coordinate Data".
4. Select "S-O data" and press **[▲S-O]** until <S-O Ht.> is displayed.
5. Input height from the surveying point to the position to be set out in "SO dist".
6. After inputting the data, press **[OK]**.

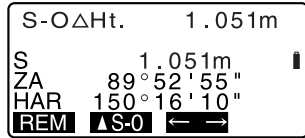

7. Press **[REM]** to begin REM setting-out measurement. Move the telescope to find the point to be set out.
-  "14.2 Distance Setting-out Measurement", steps 9 to 10



-  : Move the telescope near the zenith.
-  : Move the telescope near the nadir.

8. When the measurement is completed, press **{ESC}** to restore <S-O>.

15. SETTING-OUT LINE

Setting-out line is used for setting out a required point at a designated distance from the baseline and for finding the distance from the baseline to a measured point.

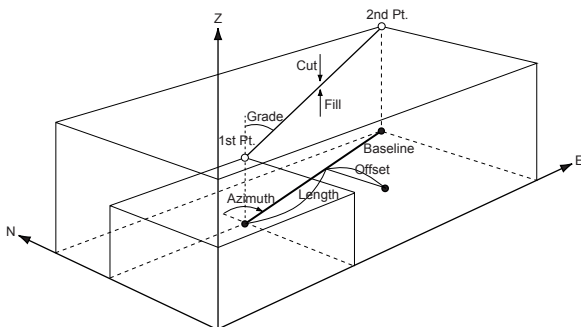

15.1 Defining Baseline

To perform setting-out line measurement, first, define the baseline. The baseline can be defined by inputting the coordinates of the two points. The scale factor value is the difference between the input coordinates and the observed coordinates.

Scale (X, Y) = $\frac{\text{Hdist}' \text{ (horizontal distance calculated from the measured value)}}{\text{Hdist} \text{ (horizontal distance calculated from the input coordinates)}}$

- When not observing first or second points, scale factor is set to "1".
- Defined baseline can be used in both setting-out line measurement and point projection.

► PROCEDURE

1. Allocate the **[S-O LINE]** to the Meas mode screen.
☞ "25.2 Allocating Key Functions"
2. Press **[S-O LINE]** to display <Set-out line>.

3. Enter the instrument station data.

 "12.1 Entering Instrument Station Data PROCEDURE Reading in Registered Coordinate Data".

4. Select "Define baseline" in <Set-out line>.

- When **[READ]** is pressed, registered coordinates can be recalled and used.

 "12.1 Entering Instrument Station Data PROCEDURE Reading in Registered Coordinate Data"

Define 1st Pt.		
Np:	113.464	
Ep:	91.088	
Zp:	12.122	
READ	REC	OK

5. Enter the first point data and press **[OK]**.

6. Enter the second point data.

Define 2nd Pt.		
Np:	112.706	
Ep:	104.069	
Zp:	11.775	
READ	REC	OK ^{P1}

7. Press **{FUNC}**.
[MEAS] is displayed.

- When not observing the first point and the second point, go to step 14.

Define 2nd Pt.		
Np:	112.706	
Ep:	104.069	
Zp:	11.775	
		MEAS ^{P2}

8. Press **[MEAS]** on the screen of step 8 to move to observation of the first point.

Measure 1st Pt.		
N	113.464	
E	91.088	
Z	12.122	
OBS		

15. SETTING-OUT LINE

9. Sight the first point and press **[OBS]**.
The measurement results are displayed on the screen.
- Press **[STOP]** to stop the measurement.
 - You can input target height here.
10. Press **[YES]** to use the measurement results of the first point.
- Press **[NO]** to observe the first point again.
11. Sight the second point and press **[OBS]**.

12. Press **[YES]** to use the measurement results of the second point.
The distance between the two measured points, the distance calculated from inputting the coordinates of two points and the scale factors are displayed.

Azimuth	93°20'31"	
Hcalc	13.003m	
Hmeas	13.004m	
ScaleX	1.000091	
ScaleY	1.000091	
Sy=1	Sy=Sx	OK

Grade	%-2.669	▲
1:**	%	OK

13. Press **[OK]** on the screen of step 12 to define the baseline. <Set-out line> is displayed. Move to setting-out line measurement.
-  "15.2 Setting-out Line Point"/
"15.3 Setting-out Line Line"

Set-out line
Point
Line

- Press **[Sy=1]** to set scale factor y to "1".
- Press **[1 : **]** to change the grade display mode to "1 : ** = elevation : horizontal distance".



- It is also possible to perform setting-out line measurement by pressing **[MENU]** on page 2 of the Meas mode screen, then selecting "Set-out line" without allocating the function key.

15.2 Setting-out Line Point

Setting-out line point measurement can be used to find the required point coordinate by inputting the length and offset based on the baseline.

- Before performing setting-out line point, the baseline must be defined.

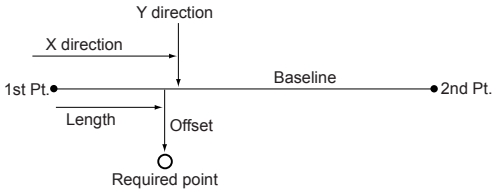

►PROCEDURE

- Select "Point" in <Set-out line>
- Set the following items.
 - Length: Distance along the baseline from the first point to the position at which a line extending from the required point intersects the baseline at right angles (X direction).
 - Offset: Distance from the required point to the position at which a line extending from the required point intersects the baseline at right angles (Y direction).

Set-out line	
Length	3.678m
Offset	1.456m
OK	

15. SETTING-OUT LINE

3. Press **[OK]**. The coordinate value of the required point is calculated and displayed.

Set-out line	
N	111.796
E	94.675
Z	12.024
REC ▲S-O	

- **[REC]**: records the coordinate value as a known point data.
☞ Recording method:
"23.1 Registering/Deleting
Known Point Data"
- Press **▲S-O** to move to setting-out measurement of the required point.
☞ "14. SETTING-OUT
MEASUREMENT"

4. Press **{ESC}**. Continue the measurement (repeat steps from 2).

15.3 Setting-out Line Line

Setting-out line line measurement tells how far horizontally the measured point is from the baseline and how far vertically the measured point is from the connected line. The baseline can be offset in a horizontal direction if necessary.

- Before performing setting-out line line, the baseline must be defined.

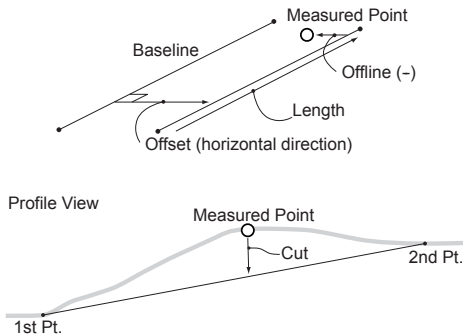

►PROCEDURE

1. Select "Line" in <Set-out line>.

2. Enter the offset value.

- Offset: How much to move the baseline.
A positive value indicates right side and a negative value indicates left side.
- When not setting offset value, go to step 3.

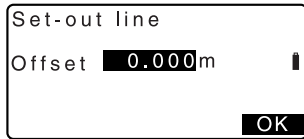

3. Sight the target and press **[OBS]** on the screen of step 2.
The measurement results are displayed on the screen.
Press **[STOP]** to stop the measurement.

4. Press **[YES]** to use the measurement results.
Displays the difference between the measured point and the baseline.

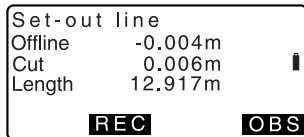

- Offline: A positive value indicates the point is on the right of the baseline and a negative value indicates it is on the left.
- "Cut" indicates that the point is below the baseline.
- "Fill" indicates that the point is above the baseline.
- Length: Distance along the baseline from the first point to the measured point.
- Press **[NO]** to observe the target again.

15. SETTING-OUT LINE

5. Sight the next target and press **[OBS]** to continue the measurement.

- Press **[REC]**: records measurement results.

 Recording method:
"21. RECORDING DATA -
RECORD MENU -"

16. SETTING-OUT ARC

This mode allows the operator to define an arc from various arc parameters, such as From Pt. coordinates, and set out this arc as well as points (offsets) along it.

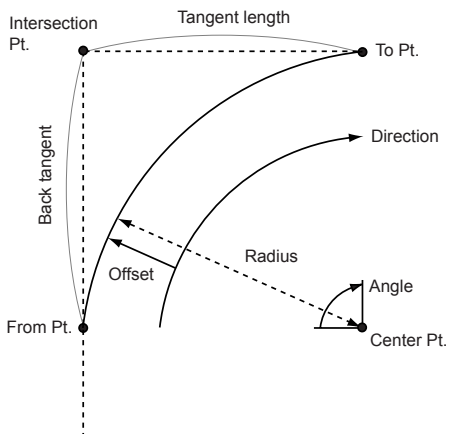

16.1 Defining an Arc

An arc can be defined by entering arc parameters such as arc radius, angle, coordinates for the From point, Center point, To point etc.

► PROCEDURE

1. In the second page of the Meas mode screen, press [MENU], then select "Set-out arc".

```
REM
Resection
Area calculation
Set-out line
Set-out arc
Point projection
```

2. Enter the instrument station data.
☞ "12.1 Entering Instrument Station Data PROCEDURE Reading in Registered Coordinate Data"

16. SETTING-OUT ARC

3. Select "Define arc" in <Set-out arc>.

- When **[READ]** is pressed, registered coordinates can be recalled and used.

 "12.1 Entering Instrument Station Data PROCEDURE Reading in Registered Coordinate Data"

```
Set-out arc
Stn.Orientation
Define arc
Set-out arc
```

4. Enter the arc From point data and press **[OK]**.

```
From Pt.
Np: 0.000
Ep: 0.000
Zp: 0.000
READ REC EDIT OK
```

5. Press **[▶]/[◀]** to select coordinates then press **[OK]**.

- To : Enter arc To point.
To/Center : Enter arc To point and Center point.
To/Intersect : Enter arc To point and Intersect point (intersection of the tangents).
Center : Enter arc Center point.
Intersect : Enter arc Intersect point.
Center/Intersect: Enter arc Center point and Intersect point (intersection of the tangents).

```
Select Pt.
To
OK
```

```
Select Pt.
Center/Intersect
OK
```

6. Enter the coordinates specified in step 5 then press **[←]**.

- When entering multiple coordinates, the right arrow is displayed.

```
To Pt.
Np: 0.000
Ep: 0.000
Zp: 0.000
READ REC EDIT OK
```

7. Enter other arc parameters.

- (1) Direction (whether the arc turns right/left from the From point)
- (2) Radius (radius of the arc)
- (3) Angle (subtended angle)
- (4) Arc (distance along the arc)
- (5) Chord (straight line distance between the From and To points)
- (6) Tan In (tangent length)
- (7) Bk tan (back tangent length)

Direction:	Left
Radius:	<Null>
Angle :	<Null>
Arc :	<Null>
Chord :	141.421m
OK	

Tan In:	<Null>
Bk tan:	<Null>
EDIT OK	



Parameters that can be entered may be restricted depending on the coordinates specified in step 5.

"Specifying coordinates and curve parameters"

8. Enter curve parameters then press . Other parameters will be calculated.

Direction:	Right
Radius :	100.000m
Angle :	90°00'00"
Arc :	157.080m
Chord :	141.421m
OK	

9. Press **[OK]** on the screen of step 8 to define the arc. <Set-out arc> is displayed. Move to setting-out arc measurement.

"16.2 Setting-out Arc" step 2



- It is also possible to perform setting-out arc measurement by pressing **[S-O ARC]** when allocated to the Meas mode screen.

Allocating **[S-O ARC]**: "25.2 Allocating Key Functions"

16. SETTING-OUT ARC



Specifying coordinates and curve parameters

Parameters that can be entered may be restricted depending on the coordinates specified in step 5. Parameters that can be entered are marked with a circle (○). Those that cannot are marked with a cross (×).

Parameters \ Set coord	Radius	Angle	Arc	Chord	Tan In	Bk tan	Direction
To pt Center pt	×	×	×	×	×	×	○
To pt Intersect pt	×	×	×	×	×	×	○
Center pt Intersect pt	×	×	×	×	×	×	○
To pt	○	○	○	×	○	○	○
Center pt	×	○	○	○	○	×	○
Intersect pt	○	○	×	○	×	×	○



Precaution when performing setting-out arc

In the following cases parameters cannot be calculated:

$$\text{when Radius} < \frac{\text{Chord}}{2}$$

When Arc < Chord

When Tan In × 2 < Chord

When the included angle between the back tangent and the azimuth angle between the From Pt. and To Pt is 0°, or exceeds 180°.

16.2 Setting-out Arc

Setting-out arc measurement can be used to find the coordinates of required points along the arc by inputting the arc (or chord) length and offset based on the arc.

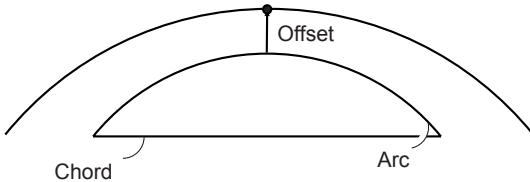

- Before performing setting-out arc, the arc must be defined.

►PROCEDURE

1. Select "Set-out arc" in <Set-out arc>.
2. Set the following items.
 - (1) Arc: Distance along the defined arc from the From point to the required point.
 - (1) Chord: Distance along the chord of the defined arc from the From point to the required point.
 - (2) Offset: Distance from the required point to the position on a curve parallel to the original defined arc. A positive value indicates an offset arc to the right, and a negative value indicates an arc to the left.

```
Set-out arc
Stn.Orientation
Define arc
Set-out arc
```

```
Set-out arc
Arc : 20.000m
Offset : 5.000m
CHORD EDIT OK
```



16. SETTING-OUT ARC

- Press **[CHORD]** to switch to Chord input.

Set-out arc	
Chord :	0.000m
Offset :	0.000m
ARC	EDIT OK

3. Press **[OK]** on the screen of step 2. The coordinate value of the required point is calculated and displayed.

Set-out arc	
N	118.874
E	106.894
Z	12.546
REC	▲S-O

- **[REC]**: records the coordinate value as a known point data.
 Recording method:
"23.1 Registering/Deleting Known Point Data"
- Press **▲S-O** to move to setting-out measurement of the required point.
 "14. SETTING-OUT MEASUREMENT"

4. Press **{ESC}**. Continue the measurement (repeat steps from 2).

17. POINT PROJECTION

Point projection is used for projecting a point onto the baseline. The point to project can be either measured or input. Displays the distances from the first point and point to project to the position at which a line extending from point to project intersects the baseline at right angles.

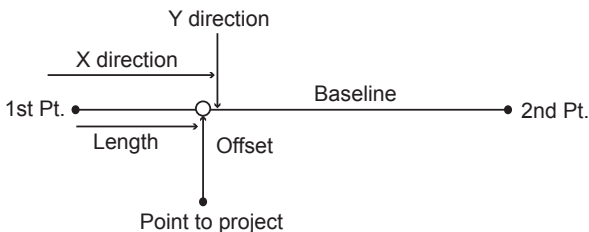

17.1 Defining Baseline

- Defined baseline can be used in both setting-out line measurement and point projection.

► PROCEDURE

1. In the second page of the Meas mode screen, press **[MENU]**, then select "Point Projection".
2. Enter the instrument station data then define the baseline.
☞ "15.1 Defining Baseline" steps 3 to 14
3. Press **[OK]** to define the baseline. <Point Projection> is displayed. Move to point projection measurement.
☞ "17.2 Point Projection"

Point projection		
Np:	103.514	
Ep:	101.423	
Zp:	12.152	
READ OBS		P1
OK		

17. POINT PROJECTION



- It is also possible to perform setting-out line measurement by pressing **[MENU]** on page 2 of the Meas mode screen, then selecting "Point Projection" without allocating the function key.

17.2 Point Projection

Before performing point projection, the baseline must be defined.

►PROCEDURE

1. Define the baseline.
 "17.1 Defining Baseline"
2. Select "Point Projection" in <Point projection>.

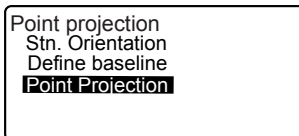

3. Enter the point coordinate.
 - Press **[OBS]** to observe the point to project.
 - When recording the data as a known point, press **{FUNC}**, and then press **[REC]** on the second page.

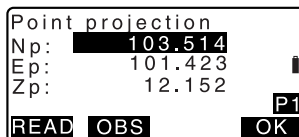

Recording method:
"23.1 Registering/Deleting
Known Point Data"

4. Press **[OK]** on the screen of step 3.
The following items are calculated and displayed.

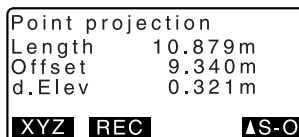

- Length: Distance along the baseline from the first point to the projected point (X direction).

- Offset: Distance from point to project to the position at which a line extending from point of project intersects the baseline at right angles. (Y direction).
- d.Elev: Elevation between the baseline and the projected point.
- Press **[XYZ]** to switch the screen display to coordinate values.
- Press **[OFFSET]** to switch the screen display to distance values.
- Press **[REC]**: records the coordinate value as a known point data.

 Recording method:
"23.1 Registering/Deleting
Known Point Data"

- Press **[▲ S-O]** to move to setting-out measurement of the projected point.

 "14. SETTING-OUT
MEASUREMENT"

5. Press **{ESC}**. Continue the measurement (repeat steps from 3).

18. OFFSET MEASUREMENT

Offset measurements are performed in order to find a point where a target cannot be installed directly or to find the distance and angle to a point which cannot be sighted.

- It is possible to find the distance and angle to a point you wish to measure (target point) by installing the target at a location (offset point) a little distance from the target point and measuring the distance and angle from the surveying point to the offset point.
- The target point can be found in the three ways explained below.

18.1 Single-distance Offset Measurement

Finding it by entering the horizontal distance from the target point to the offset point.

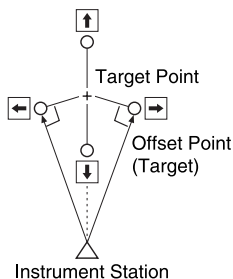

- When the offset point is positioned to the left or right of the target point, make sure the angle formed by lines connecting the offset point to the target point and to the instrument station is almost 90° .
- When the offset point is positioned in front of or behind the target point, install the offset point on a line linking the instrument station with the target point.

► PROCEDURE

1. Set the offset point close to the target point and measure the distance between them, then set up a prism on the offset point.

2. Sight the offset point and press **[DIST]** in the first page of the Meas mode screen to begin measurement.
The measurement results are displayed. Press **[STOP]** to stop the measurement.
3. Press **[OFFSET]** in page three of Meas mode to display <Offset>.
4. Enter the instrument station data.
 "12.1 Entering Instrument Station Data PROCEDURE Reading in Registered Coordinate Data"

5. Select "Offset/Dist".
Input the following items.
 - (1) Horizontal distance from the target point to the offset point.
 - (2) Direction of the offset point.

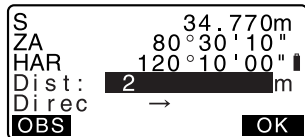

- Direction of offset point
 - ← : On the left of the target point.
 - : On the right of the target point.
 - ↓ : Closer than the target point.
 - ↑ : Beyond the target point.
- Press **[OBS]** to re-observe the offset point.

6. Press **[OK]** to calculate and display the distance and angle of the target point.

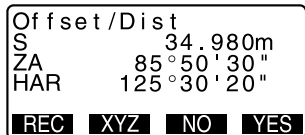

18. OFFSET MEASUREMENT

- Press **[YES]** to return to <Offset>.
 - Press **[XYZ]** to switch the screen display from distance values to coordinate values. Press **[HVD]** to return to distance values.
 - Press **[No]** to return to the previous distance and angle.
 - To record the calculation result, press **[REC]**.

 "21. RECORDING DATA -
RECORD MENU -"

18.2 Angle Offset Measurement

Sighting the direction of the target point to find it from the included angle. Install offset points for the target point on the right and left sides of and as close as possible to the target point and measure the distance to the offset points and the horizontal angle of the target point.

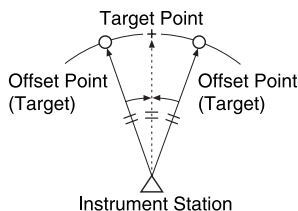

► PROCEDURE

- Set the offset points close to the target point (making sure the distance from the instrument station to the target point and the height of the offset points and the target point are the same), then use the offset points as the target.

2. Sight the offset point and press **[DIST]** in the first page of the Meas mode screen to begin measurement.
The measurement results are displayed. Press **[STOP]** to stop the measurement.
3. Press **[OFFSET]** in page three of Meas mode to display <Offset>.
4. Enter the instrument station data.
 "12.1 Entering Instrument Station Data PROCEDURE Reading in Registered Coordinate Data".
5. Select "Offset/Angle" in <Offset>.
6. Accurately sight the direction of the target point and press **[OK]**.
The distance and angle of the target point are displayed.
7. After finishing measurement, press **[YES]** to return to <Offset>.

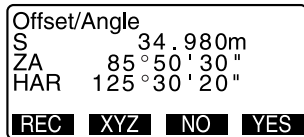
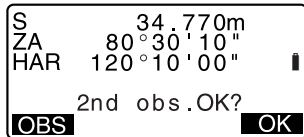

18.3 Two-distance Offset Measurement

By measuring the distances between the target point and the two offset points. Install two offset points (1st target and 2nd target) on a straight line from the target point, observe the 1st target and 2nd target, then enter the distance between the 2nd target and the target point to find the target point.

- It is possible to make this measurement easily using the optional equipment: the 2-point target (2RT500-K). When using this 2-point target, be sure to set prism constant to 0.

 "25.1 Changing Instrument Options • EDM settings"

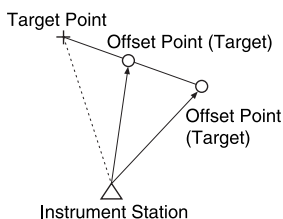

How to use 2-point target (2RT500-K)

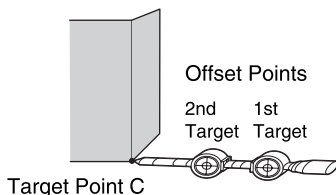

- Install the 2-point target with its tip at the target point.
- Face the targets toward the instrument.
- Measure the distance from the target point to the 2nd target.
- Set the reflector type to "sheet".

► PROCEDURE

- Install two offset points (1st target, 2nd target) on a straight line from the target point and use the offset points as the target.

2. Press **[OFFSET]** in page three of Meas mode to display <Offset>.
3. Enter the instrument station data.
 "12.1 Entering Instrument Station Data PROCEDURE Reading in Registered Coordinate Data".
4. Select "Offset/2D" in <Offset>.

5. Sight the 1st target and press **[OBS]**.
 Observation begins and the measurement results are displayed.
 Press **[YES]**. The "2nd Target Observation Screen" is displayed.

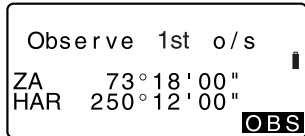

6. Sight the 2nd target and press **[OBS]**.
 The measurement results are displayed. Press **[YES]**.

7. Enter the distance from the 2nd target to the target point and press **[←]**. The coordinates of the target point are displayed.



8. Press **[YES]**. <Offset> is restored.

- When **[HVD]** is pressed, display mode is switched from coordinates to S, ZA, HAR.

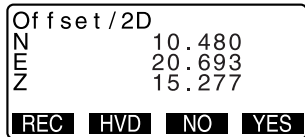

19. MISSING LINE MEASUREMENT

Missing line measurement is used to measure the slope distance, horizontal distance, and horizontal angle to a target from the target which is the reference (starting point) without moving the instrument.

- It is possible to change the last measured point to the next starting position.
- Measurement result can be displayed as the gradient between two points.

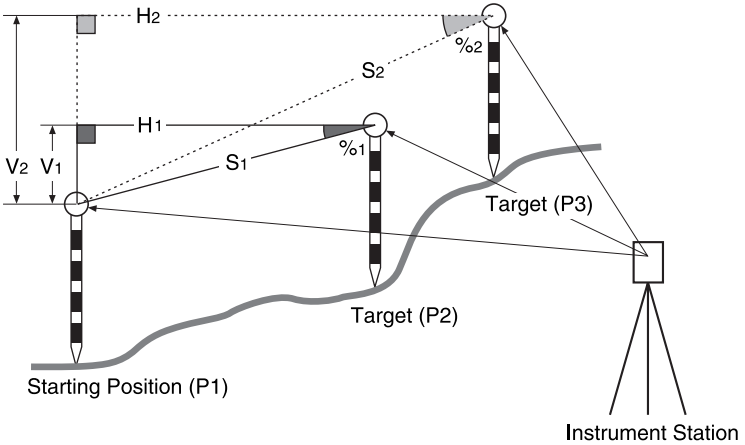

19.1 Measuring the Distance between 2 or more Points

► PROCEDURE

1. Sight the target of the starting position, and press **[DIST]** in the first page of Meas mode to begin measurement.
The measured values are displayed.
Press **[STOP]** to stop measurement.

2. Sight the second target and press **[MLM]** in the third page of Meas mode to begin observation.

The following values are displayed:

S : Slope distance of the starting position and 2nd target.

H : Horizontal distance of the starting position and 2nd position.

V : Height difference of the starting position and 2nd target.

- Target height of the starting position and second target can be input. Press **[TARGET]** on the second page.

Input the target heights and press **[OK]**.

MLM			
S	27.757m		█
H	20.345m		
V	1.012m		P1
[MLM]	[MOVE]	[S%]	[OBS]

MLM			
S	20.757m		█
H	27.345m		
V	1.012m		P2
			[TARGET]

Target height			
Pt.1	█	1.500m	
Pt.2		1.500m	
			[OK]

19. MISSING LINE MEASUREMENT

3. Sight the next target and press **[MLM]** to begin observation. Slope distance, horizontal distance and height difference between multiple points and the starting position can be measured this way.

- When **[S/%]** is pressed, the distance between two points (S) is displayed as the gradient between two points.
- Press **[OBS]** to re-observe the starting position. Sight the starting position and press **[OBS]**.
- When **[MOVE]** is pressed, the last target measured becomes the new starting position to perform missing line measurement of the next target.

 "19.2 Changing the Starting Point"

4. Press **{ESC}** to end missing line measurement.

19.2 Changing the Starting Point

It is possible to change the last measured point to the next starting position.

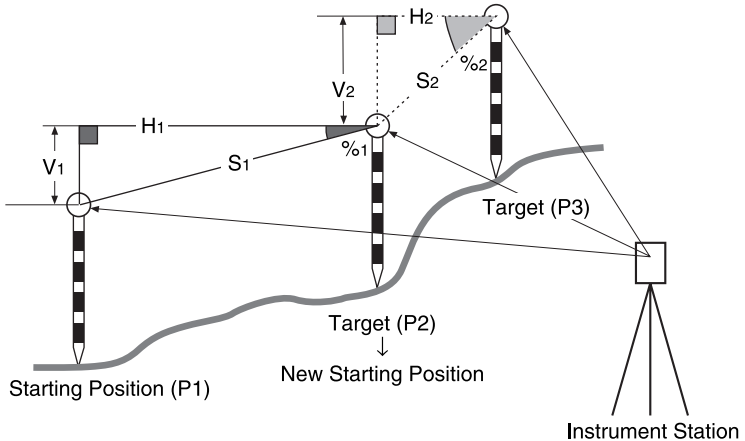

► PROCEDURE

1. Observe the starting position and target following steps 1 to 3 in "19.1 Measuring the Distance between 2 or more Points".
2. After measuring the targets, press **[MOVE]**.
Press **[YES]**.
 - Press **[NO]** to cancel measurement.
3. The last target measured is changed to the new starting position.
Perform missing line measurement following steps 2 to 3 in "19.1 Measuring the Distance between 2 or more Points".

20. SURFACE AREA CALCULATION

You can calculate the area of land (slope area and horizontal area) enclosed by three or more known points on a line by inputting the coordinates of the points.

Input

Coordinates: P1 (N1, E1, Z1)
P2 (N1, E2, Z2)
P3 (N3, E3, Z3)

Output

Surface area: S (slope area and horizontal area)

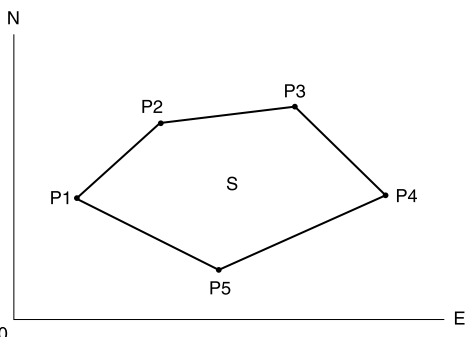

- Number of specified coordinate points: 3 or more, 50 or less
- Surface area is calculated by observing the points on a line enclosing an area in order or reading in the previously registered coordinates in order.



- If two or less points are used to measure an area, an error will occur.
- Be sure to observe (or recall) points on an enclosed area in a clockwise or counterclockwise direction. For example, the area specified by entering (or recalling) point numbers 1, 2, 3, 4, 5 or 5, 4, 3, 2, 1 implies the same shape. However, if points are not entered in numerical order, the surface area will not be calculated correctly.



Slope area

The first three points specified (measured/read-in) are used to create the surface of the slope area. Subsequent points are projected vertically onto this surface and the slope area calculated.

►PROCEDURE Surface area calculation by observing points

1. In the second Meas mode screen, press **[MENU]**, then select "Area calculation".

```
REM
Resection
Area calculation
Set-out line
Point projection
```

2. Enter the instrument station data.
 "12.1 Entering Instrument Station Data PROCEDURE Reading in Registered Coordinate Data"

3. Select "Area calculation" in <Area calculation>.

```
Area calculation
Stn. Orientation
Area Calculation
```

4. Sight the first point on the line enclosing the area, and press **[MEAS]**.
 Press **[OBS]** to begin observation.
 The measured values are displayed.

```
01:
02:
03:
04:
05:
READ MEAS
```

```
N          12.345
E          137.186
Z          1.234
ZA  90°01'25"
HAR 109°32'00"
OK OBS
```

5. Press **[OK]** to enter the value of point 1 in "Pt.01".

```
01: Pt_01
02:
03:
04:
05:
MEAS
```

20. SURFACE AREA CALCULATION

6. Repeat steps 4 to 5 until all points have been measured. Points on an enclosed area are observed in a clockwise or counterclockwise direction.

For example, the area specified by entering point numbers 1, 2, 3, 4, 5 or 5, 4, 3, 2, 1 implies the same shape.

After all known points necessary to calculate the surface area have been observed, **[CALC]** is displayed.

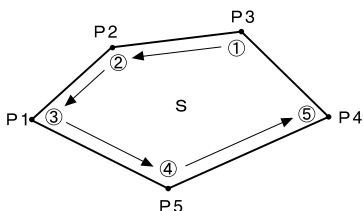

7. Press **[CALC]** to display the calculated area.

Pt.: number of set points

SArea: slope area

HArea: horizontal area

```
01: Pt_01
02: Pt_02
03: Pt_03
04: Pt_04
05: Pt_05
  CALC      MEAS
```

```
Pt. 5
SArea 468.064m2
       0.0468ha
HArea 431.055m2
       0.0431ha
      OK
```

8. Press **[OK]** in the screen of Step 7 to quit area calculation and return to Meas Mode.

► PROCEDURE Surface area calculation by reading in the points' coordinates

1. In the second Meas mode screen, press **[MENU]**, then select "Area calculation".
2. Enter the instrument station data.
3. Select "Area calculation" in <Area calculation>.

4. Press **[READ]** to display the list of coordinate data.

Pt. : Known point date
saved in the current
JOB or in the
Coordinate Search
JOB.

Crd./ Stn : Coordinate data saved
in the current JOB or in
the Coordinate Search
JOB.



5. Select the first point in the list and press **{←}**.
The coordinates of the first point is set as "Pt.001".

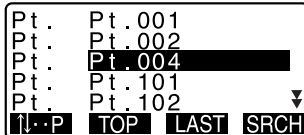

6. Repeat steps 4 to 5 until all points have been read in.
Points on an enclosed area are read in a clockwise or counterclockwise direction.
After all known points necessary to calculate the surface area have been observed, **[CALC]** is displayed.

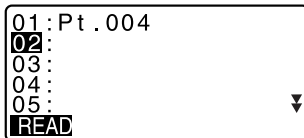

20. SURFACE AREA CALCULATION

7. Press **[CALC]** to display the calculated area.

Pt .3	
SArea	468.064m ²
	0.0468ha
HArea	431.055m ²
	0.0431ha
	OK

8. Press **[OK]** to quit area calculation and return to Meas Mode.

Note

- It is also possible to perform area measurement by pressing **[AREA]** when allocated to the Meas mode screen.

 Allocating **[AREA]**: "25.2 Allocating Key Functions"

21. RECORDING DATA - RECORD MENU -

In Record menu, you can store the measurement data (distance, angle, coordinates), station point data, backsight station and note in the current JOB.

 "22. SELECTING/DELETING A JOB"

- A total of 10000 data can be stored inside the instrument.



- If the same point number is input, the following screen is displayed. Recording backsight station is an exception.

N	5.544
E	-0.739
Z	0.245
Pt.	PNT-001
	Overwrite ?
ADD	NO YES

Press **[ADD]** to record the point as another record with the same name.

Press **[NO]** to input a new name.

Press **[YES]** to overwrite the present point.

21.1 Recording Instrument Station Data

Instrument station data can be stored in the current JOB.

- The items that can be recorded are the instrument station coordinates, point number, instrument height, codes, operator, date, time, weather, wind, temperature, air pressure and atmospheric correction factor.
- If instrument station data is not stored for the current JOB, the previously stored instrument data settings will be used.

► PROCEDURE

1. Press **[REC]** in the third page of Meas mode to display <REC>.
 - Current JOB name is displayed.
 2. Select "Stn. data".
 - Select **[READ]** to recall and use the registered coordinates.
-  "12.1 Entering Instrument Station Data PROCEDURE Reading in Registered Coordinate Data"

21. RECORDING DATA - RECORD MENU -

3. Set the following data items.
- (1) Instrument station coordinates
 - (2) Point number
 - (3) Instrument height
 - (4) Code
 - (5) Operator
 - (6) Date
 - (7) Time
 - (8) Weather
 - (9) Wind
 - (10) Temperature
 - (11) Air pressure
 - (12) Atmospheric correction factor

- When inputting code, **[ADD]**, **[LIST]** and **[SRCH]** are displayed.

Press **[ADD]** to save input codes in memory.

Press **[LIST]** to display saved codes in reverse chronological order.

Press **[SRCH]** to search for a saved code.

-  For reviewing and saving codes in Memory mode, see "23.1 Registering/Deleting Known Point Data" and "23.4 Reviewing Codes"

- To set the atmospheric correction factor to 0ppm, press **[0ppm]**. The temperature and air pressure are set to the default setting.

4. Check the input data, then press **[OK]**.
5. Press **{ESC}** to restore <REC>.

N0 :	56.789	
E0 :	-1234567.789	
Z0 :	1.234	
Pt. :	Pt.004	
Inst.h :	1.234m	▼
[OK]	[READ]	

Code	▲
: pole	A
Operator	
: SOKKIA	
[OK]	[ADD] [LIST] [SRCH]

Date	: Jan/28/2006	▲
Time	: 00:00:00	
Weath	: Fine	
Wind	: Calm	▼
[OK]		

Temp.	: 12°C	▲
Press.	: 1013hPa	
ppm	: -3	
[OK]	[0ppm]	



- Maximum point number size: 14 (alphanumeric)
- Input range of target height: -9999.999 to 9999.999 (m)
- Maximum code/operator size: 16 (alphanumeric)
- Weather selection: Fine, Cloudy, Light rain, Rain, Snow
- Wind selection: Calm, Gentle, Light, Strong, Very strong
- Temperature range: -30 to 60 (°C) (in 1°C step)/-22 to 140 (°F) (in 1°F step)
- Air pressure range: 500 to 1400 (hPa) (in 1 hPa step)/375 to 1050 (mmHg) (in 1mmHg step)/14.8 to 41.3 (inch Hg) (in 0.1 inch Hg step)
- Atmospheric correction factor range (ppm): -499 to 499

Date: Entry example	July 20, 2007 → 20070720
Time:Entry example:	2:35:17 p.m. → 143517

21.2 Recording Backsight Point

Backsight station data can be stored in the current JOB. Azimuth angle setting method can be selected from "inputting azimuth angle" or "calculating coordinates".

►PROCEDURE Inputting azimuth angle

1. Press **[REC]** in the third page of Meas mode to display <REC>.
2. Select "Backsight data".

```
REC JOB1
  Stn. data
  Backsight data
  Angle data
  Dist data
  Coord data
```

3. Select "Angle".
Angle measurement values are displayed in real time.

```
REC / Backsight
  Angle
  Coord
```

21. RECORDING DATA - RECORD MENU -

4. Input Azimuth angle.

REC/Backsight	
Take BS	
ZA	90° 12' 34"
HAR	130° 12' 34"
HAR:	0.0000
REC	

5. Sight the backsight and press **[REC]** in the screen of step 4, and set the following items.

- (1) Code
- (2) Target height
- (3) Point number

ZA	90° 12' 34"	A
HAR	0° 00' 00"	
Cd		
Tgt.h	0.000m	▼
OK ADD LIST SRCH		

6. Check the input data, then press **[OK]** to set the backsight station. <REC> is restored.

Pt.		1	A
OK			

►PROCEDURE Calculating azimuth angle by coordinates

1. Press **[REC]** in the third page of Meas mode to display <REC>.
2. Select "Backsight data".
3. Select "Coord".

REC / Backsight	
Angle	
Coord	

4. Input the backsight station coordinates.
- When you wish to read in and set coordinate data from memory, press **[READ]**.

REC/Backsight	
NBS :	1.000
EBS :	1.000
ZBS :	<Null>
READ OK	

 "12.1 Entering Instrument Station Data PROCEDURE Reading in Registered Coordinate Data"

5. Press **[OK]** in the screen of step 3. Angle measurement values are displayed in real time. Calculated Azimuth angle is also displayed.

```
REC/Backsight
Take BS
ZA 90°12'34"
HAR 123°12'34"
Azimuth 45°00'00"
REC
```

6. Sight the backsight and press **[REC]** in the screen of step 4, and set the following items.

- (1) Code
- (2) Target height
- (3) Point number

```
ZA 90°12'34" A
HAR 45°00'00"
Cd [REDACTED]
Tgt.h 0.000m
OK ADD LIST SRCH
```

```
Pt. [REDACTED] 1 A
OK
```

7. Check the input data, then press **[OK]** to set the backsight station. <REC> is restored.

21.3 Recording Angle Measurement Data

Angle measurement data can be stored in the current JOB.

- It is convenient to use **[AUTO]** to perform automatic operation from angle measurement to recording.

►PROCEDURE

1. Press **[REC]** in the third page of Meas mode to display <REC>.
2. Select "Angle data" and sight the point to be recorded. Angle measurement values are displayed in real time.

```
REC/Angle rec 2922
ZA 60°15'40" I
HAR 110°30'45"
Pt. Pt.002
AUTO 0SET REC
```

21. RECORDING DATA - RECORD MENU -

3. Press **[REC]** in the screen of step 2 then set the following items.

- (1) Code
- (2) Target height
- (3) Point number

ZA	60°15'40"
HAR	110°30'45"
Cd	1010
Tgt.h	1.234m
OK	ADD LIST SRCH

Pt.	Pt.002	▲
		A
OK		

4. Check the input data, then press **[OK]**.
5. To continue measurement, sight the next point, then perform steps 3 and 4 above.

- Press **[AUTO]** to perform angle measurement and automatically record the results. **[AUTO]** is convenient for recording measurement data when point number, code, and target height are not set.

REC/Angle	rec 2923
ZA	80°30'15"
HAR	120°10'00"
Pt.	Pt.001
	Recorded

6. Press **{ESC}** to quit measurement and restore <REC>.

21.4 Recording Distance Measurement Data

Distance measurement data can be stored in the current JOB.

►PROCEDURE

- Press **[DIST]** in the first page of Meas mode to perform distance measurement.
 "11.1 Distance and Angle Measurement"
- Press **[REC]** in the third page of Meas mode. <REC> is displayed. Select "Dist data" to display the measurement results.

```

REC JOB1
  Stn. data
  Backsight data
  Angle data
  Dist data
  Coord data
  
```

- Press **[REC]** in the screen of step 2, then set the following items.
 - Code
 - Target height
 - Point number

```

REC/Dist   rec 2923
S          123.456m
ZA        80°30'15"
HAR       120°10'00"
Pt.       Pt.001
[AUTO] [DIST] [OFFSET] [REC]
  
```

- Check the input data, then press **[OK]**.
- To continue measurement, sight the next point, press **[DIST]**, then perform steps 3 and 4 above.

```

S          123.456m
ZA        80°30'15"
HAR       120°10'00"
Cd        ██████████
Tgt.h     1.234m
[OK] [ADD] [LIST] [SRCH]
  
```

- Press **[OFFSET]** to offset measurement in Record Mode.

- Press **{ESC}** to quit measurement and restore <REC>.

```

REC/Dist   rec 2922
S          123.456m
ZA        80°30'15"
HAR       120°10'00"
Pt.       Pt.001
[AUTO] [DIST] [OFFSET]
  
```

21. RECORDING DATA - RECORD MENU -



- Once the data has been recorded, **[REC]** is not displayed in order to prevent double recording.

21.5 Recording Coordinate Data

Coordinate data can be stored in the current JOB.

►PROCEDURE

1. Perform coordinates measurement in the Meas mode screen.

"COORDINATE MEASUREMENT"

2. Press **[REC]** in the third page of Meas mode to display <REC>. Select "Coord data" to display the measurement results.

```
REC JOB1
  Stn. data
  Backsight data
  Angle data
  Dist data
  Coord data
```

3. Press **[REC]** in the screen of step 2, then set the following items.

- (1) Code
- (2) Target height
- (3) Point number

```
REC/Coord rec 2923
N          344.284
E          125.891
Z          15.564
Pt. Pt.003
[AUTO] [OBS] [OFFSET] [REC]
```

4. Check the input data, then press **[OK]**.

```
N          344.284
E          125.891
Z          15.564
Cd 1010
Tgt.h      2.000m
[OK] [ADD] [LIST] [SRCH]
```

5. To continue measurement, sight the next point, press **[OBS]**, then perform steps 3 and 4 above.

- Press **{ESC}** to quit measurement and restore <REC>.

21.6 Recording Distance and Coordinate Data

Distance measurement data and coordinate data can be stored in the current JOB at the same time.

- Both distance measurement data and coordinate data are recorded as the same point number.
- Distance measurement data is recorded first, then coordinate data is recorded.

► PROCEDURE

- Press **[REC]** in the third page of Meas mode to display <REC>.
- Select "Dist + Coord data" to display <REC/DIST + C>.

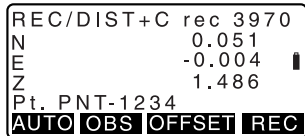
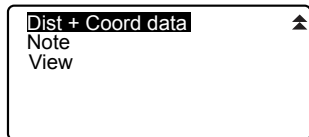

- Sight the point and press **[OBS]** to begin the measurement. The measurement results are displayed.

- Press **[REC]**, then set the following items.
 - Code
 - Target height
 - Point number

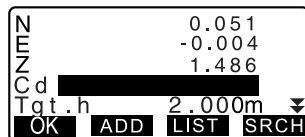

- Check the input data, then press **[OK]**.

21. RECORDING DATA - RECORD MENU -

- Press **{ESC}** to quit measurement and restore <REC>.

21.7 Recording Notes

This procedure prepares notes data and records it in the JOB which is selected.

►PROCEDURE

- Press **[REC]** in the third page of Meas mode to display <REC>. Select "Note".

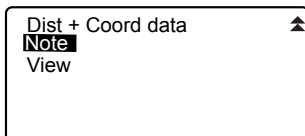

- Enter the note data.

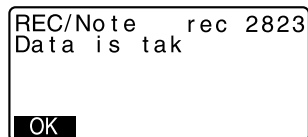

- After inputting the note data, press **[OK]** to return to <REC>.



- Maximum note length: 60 characters (alphanumeric)

21.8 Reviewing JOB Data

It is possible to display the data within the current JOB that is selected.

- It is possible to search for data within the JOB to be displayed by point number. But the note data cannot be searched.
- Known point data that are entered from an external instrument are not reviewed.

►PROCEDURE Reviewing JOB data

1. Press **[REC]** in the third page of Meas mode to display <REC>. Select "View" to display the list of recorded points.

Stn	Pt. 1
Dist	1
Cr d.	2
Dist	3
Ang.	4
↑↓·P	TOP LAST SRCH

2. Select the point number to be displayed in detail and press **[←]**. Details of the data is displayed. This screen contains distance measurement data.

S	123.456m
ZA	20°31'21"
HAR	117°32'21"
Pt. 3	
Tgt. h	12.345m
NEXT PREV	RED

- To display previous data item, press **[PREV]**.
- To display next data, press **[NEXT]**.
- **[↑↓...P]** = Use {▲}/{▼} to move from page to page.
- **[↑↓...P]**= Use {▲}/{▼} to select individual point.
- Press **[TOP]** to display first data.
- Press **[LAST]** to display last data.
- Press **[SRCH]** to search for point number. Input the point number after "Pt. No."
- The search may take time if many data are registered.

21. RECORDING DATA - RECORD MENU -

- Press **[RED]** to display the reduced data screen shown at right.
- Press **[OBS]** to return to the previous screen.

H	1234.456m	
V	-321.123m	
Azmth	12°34'56"	
Pt	3	
Tgt. h	12.345m ▼	
NEXT	PREV	OBS

3. Press **{ESC}** to conclude detailed display and restore the list of points.
Press **{ESC}** again to restore <REC>.



- If more than two points with the same point name exist in the current JOB, SET finds the newer data only.

22. SELECTING/DELETING A JOB

22.1 Selecting a JOB

Select the current JOB and Coordinate Search JOB.

- A total of 10 JOBS have been prepared, and JOB1 was selected when your SET was shipped from the factory.
- The names of the JOBS have been preset as JOB1 to JOB10; you can change them to any names you wish.
- Scale factor can be set for each JOB. Only scale factor of the current JOB can be edited.



Current JOB

Measurement results, instrument station data, known points data, notes and coordinate data are recorded in the current JOB.

 Registering known point data: "23.1 Registering/Deleting Known Point Data"



Coordinate Search JOB

The registered coordinate data in the JOB selected here can be read into coordinate measurement, resection measurement, setting-out measurement, etc.



Scale correction

SET calculates horizontal distance and coordinates of a point using measured slope distance. If scale factor has been set, scale correction is carried out during calculation.

$$\text{Corrected horizontal distance (s)} = \text{Horizontal distance (S)} \times \text{Scale factor (S.F.)}$$

- When scale factor is set to "1.00000000", the horizontal distance is not corrected.

► PROCEDURE JOB selection and scale factor setting

1. Select "JOB" in Memory Mode.

Memory
JOB
Known data
Code

22. SELECTING/DELETING A JOB

2. Select "JOB selection".
<JOB selection> is displayed.

```
JOB
JOB selection
JOB name edit
JOB deletion
Comms output
Comms setup
```

3. Press [LIST].

```
JOB selection
: JOB1
S.F.=1.00000000
Coord search JOB
: JOB
LIST S.F.
```

- JOB can also be selected on the screen of step 2 by pressing **▶**/**◀**.
- The numbers to the right represent the number of data items in each JOB.
- "*" means that the JOB has not been output to an external device yet.

```
JOB selection
JOB01 46
*ATUG1 254
JOB03 0
JOB04 0
JOB05 0▼
```

4. Align the cursor with the desired JOB as the current JOB and press **◀**.
- The JOB is determined .

5. Press [S.F.] and enter the scale factor for the current JOB.

```
JOB 1
S.F.=1.00000000
```

6. Press **◀**.
- <JOB selection> is restored.
7. Align the cursor with "Coord search JOB" and press [LIST].
- <Coord search JOB> is displayed.

- Align the cursor with the desired JOB as the coordinate search JOB and press {←}.
The JOB is determined and <JOB> is restored.

Note

- The list of JOB names is contained on up to 2 pages.
- Scale factor input range : 0.50000000 to 2.00000000 (*1.00000000)
- "*" : Factory setting

► PROCEDURE Inputting a JOB name

- Select "JOB" in Memory mode.
- Select in advance the JOB whose name is to be changed.
[F] "PROCEDURE JOB selection and scale factor setting"
- Select "JOB name edit" in <JOB>.
Input the new JOB name and press {←}.
<JOB> is restored.

```
JOB
JOB selection
JOB name edit
JOB deletion
Comms output
Comms setup
```

```
JOB name edit
JOB03
```

Note

- Maximum length of JOB name: 12 (alphanumeric)

22.2 Deleting a JOB

It is possible to clear the data within a designated JOB. After the data has been cleared, the JOB name returns to the name allocated when the SET was shipped.

22. SELECTING/DELETING A JOB



- A JOB that has not been output to an auxiliary device (displayed with *) cannot be deleted.

►PROCEDURE

1. Select "JOB" in Memory Mode.
2. Select "JOB deletion".
<JOB deletion> is displayed.

- The numbers to the right represent the number of data items in each JOB.

```
JOB
JOB selection
JOB name edit
JOB deletion
Comms output
Comms setup
```

```
JOB deletion
JOB01          46
*ATUGI        254
JOB03          0
JOB04          0
JOB05          0
```

3. Align the cursor with the desired JOB and press {←}.
JOB and press {←}.
4. Press [YES]. The data within the JOB selected is deleted and <JOB deletion> is restored.

```
JOB03
deletion
Confirm ?
NO YES
```

23. REGISTERING/DELETING DATA

23.1 Registering/Deleting Known Point Data

It is possible to register or delete coordinate data of the known points in the current JOB.

The coordinate data that has been registered can be output during setting for use as instrument station, backsight station, known point, and setting-out point coordinate data.

- It is possible to register 10000 items of coordinate data, including the data inside the JOBS.
- There are two registration methods: key entry and entry from an external instrument.
 - ☞ Communication cables: "28.2 Optional Accessories"
 - Output format and command operations: "Interfacing with the SOKKIA SDR Electronic Field Book" and "Command Explanations" manuals.
- When entering known point data from an external device, SET does not check the repeated point number.
- Communication setup can be performed in the known data as well. Select "Comms Setup" in <Known data>.



- When "inch" is selected as the distance unit, the value must be input in "feet." or "US feet" depending on the feet unit selected.

► PROCEDURE Using the key entry method to register known point coordinate data

1. Select "Known data" in Memory Mode.
 - Current JOB name is displayed.
2. Select "Key in coord" and input known point coordinates and point number.

```
Memory
JOB
Known data
Code
```

```
Known data
Job.JOB1
Key in coord
Comms input
Deletion
View
```

```
rec 3991
N 567.950
E -200.820
Z 305.740
Pt. 5
```

23. REGISTERING/DELETING DATA

3. After setting the data, press {←}.
The coordinate data is recorded in the current JOB and screen in step 2 is restored.

```
rec 2641
N 567.950
E -200.820
Z 305.740
Pt. 5
Recorded
```

4. Continue to enter other known point coordinate data.
5. After the registration of all the coordinate data has been completed, press {ESC} to restore <Known data>.

►PROCEDURE Entering known point coordinate data from an external instrument

1. Connect SET and host computer.
2. Select "Known data" in Memory Mode.
- Current JOB name is displayed.

3. Select "Comms input" to display <Comms input>.
Coordinate data starts to be entered from an external instrument and the number of received items is displayed on the screen. When data reception is completed, <Known data> is displayed.

```
Known data
Job.JOB1
Key in coord
Comms input
Deletion
View
```

```
Comms input
Format SDR
Receiving 12
```

- Press {ESC} to stop data reception in progress.

►PROCEDURE Deleting designated coordinate data

1. Select "Known data" in Memory Mode.

```
Known data
Job.JOB1
Key in coord
Comms input
Deletion
View
```

2. Select "Deletion" to display the list of known point data.

```

Pt. 0
Pt. 1
Pt. 12345678
Pt. 12345679
Pt. SOKKIA
[P] TOP LAST SRCH
  
```

3. Select the point number to be deleted and press {←}.

- [↑↓...P] = Use {▲}/{▼} to move from page to page.
- [↑↓...P] = Use {▲}/{▼} to select individual point.
- Press [TOP] to display top of point number list.
- Press [LAST] to display end of point number list.
- Press [SRCH] to search for point number. Input the point number after "Pt. No."
The search may take time if many data are registered.

```

N 567.950
E -200.820
Z 305.740
Pt. 5
NEXT PREV DEL
  
```

4. Press [DEL] to delete the selected point number.

- Press [PREV] to display previous data.
- Press [NEXT] to display next data.

5. Press {ESC} to quit the point number list and return to <Known data>.

```

Pt. no: A
  
```

23. REGISTERING/DELETING DATA

►PROCEDURE Clearing all coordinate data at once (initialization)

1. Select "Known data" in Memory Mode.
2. Select "Clear" and press {←}.

```
Known data
Job.JOB1
Clear
Comms setup
```

3. Press [YES].
<Known data> is restored.

```
Clear
Confirm ?
NO YES
```

23.2 Reviewing Known Point Data

It is possible to display all the coordinate data within the current JOB.

►PROCEDURE

1. Select "Known data" in Memory Mode.
 - Current JOB name is displayed.
2. Select "View".
The point number list is displayed.

```
Known data
Job.JOB1
Key in coord
Comms input
Deletion
View
```

```
Pt. 0
Pt. 1
Pt. 12345678
Pt. 12345679
Pt. SOKKI A
P TOP LAST SRCH
```

3. Select the point number to be displayed and press {←}.
The coordinates of the selected point number are displayed.

```

N      567.950
E     -200.820
Z      305.740
Pt.    5
NEXT  PREV      DEL

```

4. Press {ESC} to restore the point number list.
Press {ESC} again to restore <Known data>.

23.3 Registering/Deleting Codes

It is possible to save codes in memory. You can also read in codes registered in memory when recording instrument station data or observation data.

►PROCEDURE Inputting Codes

1. Select "Code" in Memory Mode.
2. Select "Key in code".
Enter the code and press {←}.
The code is registered and <Code> is restored.

```

Code
Key in code
Deletion
Code view
Clear list

```

Note

- Maximum code size: 16 (alphanumeric)
- Maximum number of codes registered: 40

```

Code
: Pole

```

►PROCEDURE Deleting codes

1. Select "Code" in Memory Mode.

23. REGISTERING/DELETING DATA

2. Select "Deletion". The registered code list is displayed.

```
Code
Key in coord
Deletion
Code view
Clear list
```

```
Pole
A001
TREE01 LEFT
POINT01
POINT02
↑ · P TOP LAST DEL
```

3. Align the cursor with the code to be deleted and press **[DEL]**.
The designated code is deleted.
4. Press **{ESC}** to restore <Code>.



- If you select "Clear list" in step 2 and then press **[YES]**, all registered codes are deleted.

23.4 Reviewing Codes

► PROCEDURE

1. Select "Code" in Memory Mode.
2. Select "Code view".
The registered code list is displayed.

```
Code
Key in coord
Deletion
Code view
Clear list
```

```
Pole
A001
Point 001
TREE01 LEFT
POINT01
↑ · P TOP LAST
```

3. Press **{ESC}** to restore <Code>.

24. OUTPUTTING JOB DATA

It is possible to output data within a JOB to a host computer or printer.

 Communication cables: "28.2 Optional Accessories"

Output format and command operations: "Interfacing with the SOKKIA SDR Electronic Field Book" and "Command Explanations" manuals.

- Measurement results, instrument station data, known point data, notes, and coordinate data in the JOB is output.
- Known point data entered from an external instrument is not output.
- Communication setup can be performed in the JOB menu as well. Select "Comms Setup" in <JOB>.



- When "inch" is selected as the distance unit, data is output in "feet" or "US feet" depending on the feet unit selected.

► PROCEDURE Outputting JOB data to host computer

1. Connect SET and host computer.

2. Select "JOB" in Memory Mode.

```
Memory
JOB
Known data
Code
```

3. Select "Comms output" to display the JOB list.

```
JOB
JOB selection
JOB name edit
JOB deletion
Comms output
Comms setup
```

4. Select the JOB to be output and press {←}.
"Out" appears to the right of the JOB selected. You can select as many JOBS as you want.

```
* JOB01      Out
  ATUG1      254
JOB03      Out
  JOB04      0
  JOB05      0
  OK
```

- "*" means the JOB has not been output to an external device yet.

5. Press [OK].

24. OUTPUTTING JOB DATA

6. Select the output format and press **{←}**.

```
Comms output
SDR33
SDR2X
Printed output
```

7. Select the output data and press **{←}**.

Output starts. When the output is complete, the JOB list is restored. It is possible to continue output of the next JOB.

- Select "Obs data" to output distance measurement data.
- Select "Reduced data" to output distance measurement data and reduced data.
- To stop output, press **{ESC}**.

```
Comms output
Obs data
Reduced data
```

►PROCEDURE Outputting JOB data to printer

1. Select "JOB" in Memory Mode.
2. Select "Comms output" to display the JOB list.

```
JOB
JOB selection
JOB name edit
JOB deletion
Comms output
Comms setup
```

3. Select the JOB to be output and press **{←}**.
"Out" appears to the right of the JOB selected. You can select as many JOBS as you want.
4. Press **[OK]**.
5. Connect SET and printer.
6. Turn ON the printer.
7. Select "Printed output" and press **{←}**.

8. Select the output data and press

{←}.

Output starts. When the output is complete, the JOB list is restored. It is possible to continue output of the next JOB.

- Select "Obs data" to output distance measurement data.
- Select "Reduced data" to output distance measurement data and reduced data.

To stop output, press {ESC}.

25. CHANGING THE SETTINGS

This section explains the contents of parameter settings, how to change settings and how to perform initialization.

25.1 Changing Instrument Options

The following explains the EDM settings and setting modes in Meas mode. Each item can be changed to meet your measurement requirements.

- "": Factory setting

● EDM settings (items set, options, and input range)

Press **[EDM]** in the second page of Meas mode.

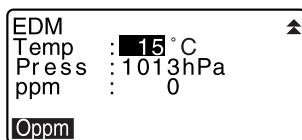
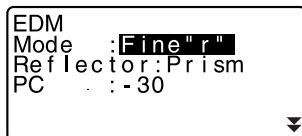

- **[Oppm]**: Atmospheric correction factor returns to 0 and temperature and air pressure are set to the default values.
- Atmospheric correction factor is calculated and set using the entered values of the temperature and air pressure. Atmospheric correction factor can also be entered directly.
-

Items set, options, and input range(*: Factory setting)

Mode (Distance measurement Mode)	Fine "r"*, Fine AVG (Setting: 1 to 9 times), Fine "s", Rapid "r", Rapid "s", Tracking
Reflector	Prism*/Sheet
PC (Prism constant)	-99 to 99 mm ("Prism" is selected: -30*, "Sheet" is selected: 0*)
Temp. (Temperature)	-30 to 60°C (15*)

Air pressure	500 to 1400hPa (1013*)/375 to 1050mmHg (760*)
ppm (Atmospheric correction factor)	-499 to 499 (0*)



Atmospheric correction factor

The SET measures the distance with a beam of light, but the velocity of this light varies according to the index of refraction of light in the atmosphere. This index of refraction varies according to the temperature and air pressure.

- To precisely determine the atmospheric correction factor, the average temperature and air pressure along the measurement beam route must be taken. Take care when calculating the correction factor in mountainous terrain as the difference in height will result in differences in atmospheric conditions between two points.
- The SET is designed so that the correction factor is 0 ppm at an air pressure of 1013 hPa, a temperature of 15°C and a humidity of 50%.
- By inputting the temperature and air pressure values, the atmospheric correction value is calculated using the following formula and set into the memory.

$$\text{ppm} = 280.098 - \frac{0.2920 \times \text{air pressure (hPa)}}{1 + 0.003661 \times \text{air temperature (}^{\circ}\text{C)}}$$

- If the weather correction is not required, set the ppm value to 0.
- The atmospheric correction factor can also be calculated in order to take humidity into account.

"30.2 Atmospheric Correction for High Precision Distance Measurement"



Prism constant correction

Reflective prisms each have their prism constant.

Set the prism constant correction value of the reflective prism you are using.

- The following are samples of the prism constant correction values of SOKKIA reflective prisms.

AP01S+AP01AR
(Constant = 30mm)

AP01AR (Constant = 40mm) CP01 (Constant = 0mm)

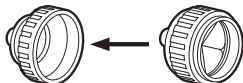

Correction Value = -30



Correction Value = -40

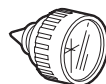

Correction Value = 0

25. CHANGING THE SETTINGS

● Settings in Config Mode (items set, options, and input range)

Select "Obs. condition" in Config mode

```
Dist mode: Sdist
Tilt crn : Yes (H,V)
coll.crn : Yes
C&R crn. : No
V manual: No
V. obs   : Zenith ▼
```

```
Coord.      : N-E-Z ▲
Ang. reso.  : 1"
Sea level crn : No
```

Dist mode	Sdist*, Hdist, Vdist
Tilt crn (Tilt angle compensation)	Yes(H,V)*, Yes(V), No
coll. crn (Collimation correction)	Yes*, No
C&R crn.	No*, K=0.142, K=0.20
V manual	Yes, No*
V.obs (Vertical angle display method)	Zenith*, Horiz, Horiz 90° (Horizontal ±90°)
Coord.	N-E-Z*, E-N-Z
Ang.reso. (Angle resolution)	SET220K/320K/520K: 1" or 5", SET620K: 1" or 5"
Sea level crn (Sea level correction)	Yes, No*



Automatic tilt angle compensation mechanism

The vertical and horizontal angles are automatically compensated for small tilt errors using the 2-axis tilt sensor.

- Read the automatically compensated angles when the display has stabilized.
- The horizontal angle error (vertical axis error) fluctuates according to the vertical axis, so when the instrument is not completely leveled, changing the vertical angle by rotating the telescope will cause the displayed

horizontal angle value to change.

Compensated horizontal angle = Measured horizontal angle + Tilt in angle/
tan (Vertical angle)

- When the telescope is directed close to the zenith or nadir angle, tilt compensation is not applied to the horizontal angle.



Collimation correction

The SET has a collimation correction function that automatically corrects horizontal angle errors caused by horizontal axis and leveling axis errors.



V mode (vertical angle display method)

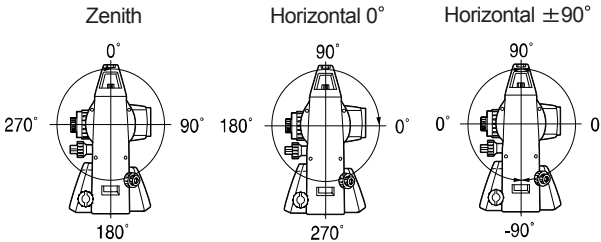

Sea level correction

The SET calculates horizontal distance using slope distance values. As this horizontal distance does not take height above sea level into consideration, performing spherical correction is recommended when measuring at high altitudes. Spherical distance is calculated as follows.

Spherical distance

$$= \frac{R - H_a}{R} \times d_1$$

Where:

R = radius of the spheroid (6372000.000m)

H_a = averaged elevation of the instrument point and target point

d_1 = horizontal distance

25. CHANGING THE SETTINGS

Select "Instr. Config" in Config mode

Power off	: 30min
Reticle lev	: 3
Contrast	: 10
Resume	: Off
EDM standby	: Off
EDM ALC	: Hold

Power off	5min, 10min, 15min, 30min*, No
Reticle lev	0 to 5 level (3*)
Contrast	0 to 15 level (10*)
Resume	On, Off*
EDM ALC	Hold*, Free



Power-saving automatic cut-off

To save power, power to the SET is automatically cut off if it is not operated for the selected time.



Resume function

When the Resume function is set to "On" and the power is switched off and then on again, the screen appearing before the instrument was switched off is redisplayed. Also, all parameter settings are saved. Memory backup period is about one week, after which the Resume function is cancelled.



EDM Standby

Set the power supply status of the EDM. When the EDM standby function is set to "ON", the EDM power status is set to standby. When **[DIST]** is pressed, you can reduce the time until the results are displayed.



EDM ALC

Set the light receiving status of the EDM. While carrying out continuous measurement, set this item according to the measurement conditions.

- When EDM ALC is set to "Free," the amount of light received is adjusted by the instrument's EDM ALC. Set to "Free" when the target is moved during measurement or different targets are used.
- When "Hold" is set, the amount of light received remains fixed until initial adjustment has been performed and continuous measurement completed.
- Try setting to "Hold" when the light beam used for measurement is stable but is frequently obstructed by obstacles such as people, cars, or tree branches etc. preventing measurement from being performed.



- The EDM ALC setting will automatically be switched to "Free" when the distance measurement mode is set to "Tracking" (target is moved during distance measurement).

Select "Comms setup" in Config mode

```
Baud rate: 1200bps
Data bits: 8bit
Parity : Not set
Stop bit : 1bit
Check sum: No
Xon/Xoff : Yes
```

Baud rate	1200bps*, 2400bps, 4800bps, 9600bps, 19200bps, 38400bps
Data bits	8bit*, 7bit
Parity	Not set*, Odd, Even
Stop bit	1bit*, 2bit
Check sum	Yes, No*
Xon/Xoff	Yes*, No

Output format and command operations: "Interfacing with the SOKKIA SDR Electronic Field Book" and "Command Operations" manuals.

Select "Unit" in Config mode

```
Temp. : °C
Press. : hPa
Angle : degree
Dist : meter
```

Temp. (Temperature)	°C*, °F
Press	hPa*, mmHg, inchHg
Angle	degree*, gon, mil
Dist	meter*, feet, inch
Feet (only displayed when "feet" or "inch" selected in "Dist")	Int. feet* (1m = 3.280839895), US feet (1m = 3.280833333)

25. CHANGING THE SETTINGS



Inch (Fraction of an inch)

"Fraction of an inch" is the unit used in the United States and expressed like the following example.

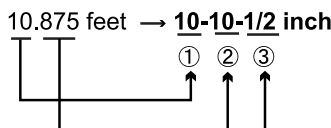

- ① 10.000 feet
- ② 0.875 feet x 12=10.5 inch
- ③ 0.5 inch=1/2 inch



- Even if "inch" is selected in this setting, all the data including the result of area calculation are output in "feet" and all the distance values must be input in "feet". In addition, when the "inch" display exceeds the range, it is displayed in "feet".



International feet and US survey feet

The SET can display feet values in International feet and US survey feet units.

International feet, the standard feet units, are referred to simply as "feet" elsewhere in this manual.

US survey feet are units used in surveys by the U.S. Coast and Geodetic Survey and are referred to as "US feet" in this manual.

When "feet" or "inch" is selected in "Dist", the "Feet" item will appear on the screen as below. When "meter" is selected, this item will not be displayed.

Temp.	: °C
Press.	: hPa
Angle	: degree
Dist	: feet
Feet	: Int. feet

Results displayed in feet will differ according to the unit selected in this item.

25.2 Allocating Key Functions

It is possible to allocate the softkeys in Meas mode to suit the measurement conditions. It is possible to operate the SET efficiently because unique softkey

allocations can be preset to suit various applications and the ways that different operators handle the instrument.

- The current softkey allocations are retained until they are revised again, even when the power is cut off.
- It is possible to register two sets of key function allocations: user setting 1 and user setting 2.
- It is possible to recall the softkey arrays registered for User 1 and User 2 as necessary.



- When softkey allocations are recorded and registered, the previously recorded key settings are cleared. When a softkey array is recalled, the key array is changed to the key array that has been recalled, clearing the previous key array. Be sure to remember this.

● The following are the softkey allocations when the SET was shipped.

Page 1 [DIST] [▲ SHV] [0SET] [COORD]

Page 2 [MENU] [TILT] [H.ANG] [EDM]

Page 3 [MLM] [OFFSET] [REC] [S-O]

● The following functions can be allocated to the softkeys.

[DIST] : Distance measurement

[▲ SHV] : Switch between angle display and distance display

[0SET] : Set horizontal angle to 0

[COORD] : Coordinates measurement

[REP] : Repetition measurement

[MLM] : Missing line measurement

[S-O] : Setting-out measurement

[OFFSET] : Offset measurement

[REC] : To Record menu

[EDM] : Setting EDM

[H.ANG] : Set required horizontal angle

[TILT] : Display tilt angle

[MENU] : To Menu mode (Coordinates measurement, setting-out measurement, offset measurement, repetition measurement, missing line measurement, REM measurement, resection measurement, surface area measurement, set-out line, set-out arc, point projection)

[REM] : REM measurement

25. CHANGING THE SETTINGS

[RESEC]	: Resection measurement
[R/L]	: Select horizontal angle right/left
[ZA / %]	: Switch between zenith angle/slope in %
[HOLD]	: Hold horizontal angle/release horizontal angle
[RCL]	: Display final measurement data
[D_OUT]	: Output measurement results to an external instrument
[AIM]	: Return signal
[AREA]	: Surface area measurement
[F/M]	: Switch between meters/feet
[HT]	: Set the instrument station height and target height
[S-O LINE]	: Setting-out line measurement
[S-O ARC]	: Setting-out arc measurement
[P-PROJ]	: Point projection measurement
[--]	: No functions set

● Softkey Allocation Examples

It is possible to allocate the same key to each page (example 1). The same function can be allocated to more than one key on the same page (example 2). And it is also possible to allocate a function to only one key (example 3).

Allocation example 1:

P1 [DIST] [▲ SHV] [H.ANG] [EDM]

P2 [DIST] [▲ SHV] [H.ANG] [EDM]

Allocation example 2:

P1 [DIST] [DIST] [▲ SHV] [▲ SHV]

Allocation example 3:

P1 [DIST] [▲ SHV] [--] [--]

► PROCEDURE Allocating functions

1. Select "Key function" in Config Mode.
Select "Define." Currently allocated softkeys are displayed in <Key function>.

- Align the cursor with the softkeys whose allocation you want to change using **▶**/**◀**. The cursor of the selected softkey flashes.

Key function			
DIST	▲SHV	0SET	COORD
MENU	TILT	H.ANG	EDM
MLM	OFFSET	REC	S-O
			OK

- Change the softkey function using **▲**/**▼**. Set the softkey function and its location by pressing **▶**/**◀**. The set softkey stops flashing and the cursor flashes on the next softkey.
- Repeat steps 2 to 3 only as many times as necessary.
- Press **[OK]** to record the allocations and restore <Key function>. The functions with their new allocations are displayed in Meas mode.

►PROCEDURE Registering an allocation

- Allocate functions to the softkeys.
☞ "PROCEDURE Allocating functions"
- Select "key function" in Config mode.
- Select "Registration."
Select either "User 1" or "User 2" as the softkey array to be registered.
- Press **←**. The softkey array is registered as user 1 or user 2 and <Key function> is restored.

Key function
User's 1
User's 2
Registered to 1

25. CHANGING THE SETTINGS

►PROCEDURE Recalling an allocation

1. Select "Key function" in Config Mode.
2. Select "Recall". Select the key array for either User 1, User 2, or Default (setting when the SET was shipped), and press {←}. <Key function> is restored. This displays the functions in the recalled array in Meas mode.

```
Key function
User's 1
User's 2
Default
```

25.3 Changing Password

Set password can be changed.

- No password was set when the SET was shipped.

►PROCEDURE Changing password

1. Select "Change Password" in Config Mode.
2. Input old password and press {←}.

```
Change password
Old password
:*****
```

3. Input new password twice and press {←}. The password is changed and <Config> is restored.

```
Change password
New password
:*****
New password again
:*****
```

- If no password was input as new password and {←} was pressed, no password is set.



- Input range of password: 3 or more characters and 8 or fewer characters

25.4 Restoring Default Settings

The following explains the two methods of restoring default settings: Restoring set items to initial settings and turning power on. Initializing the data and turning power on.

- Restore the following items to the initial settings when the SET was shipped.
EDM setting, Config mode settings (including softkey arrays)
- ☞ About initial settings when the SET was shipped, "25.1 Changing Instrument Options", "25.2 Allocating Key Functions".
- Initialize the data. The following data is initialized.
Data within all jobs
Known point data within memory
Code data within memory

► PROCEDURE Restoring set items to initial settings and turning power on

1. Turn the power off.
2. While pressing **{F4}** and **{BS}**, press **{ON}**.
3. The SET is turned on, "Default set" appears on the screen and all items are restored to their initial settings.

► PROCEDURE Initializing the data and turning the power on

1. Turn the power off.
2. While pressing **{F1}**, **{F3}** and **{BS}**, press **{ON}**.
3. The SET is turned on, "Clearing memory..." appears on the screen and all items are restored to their initial settings.

26. WARNING AND ERROR MESSAGES

The following is a list of the error messages displayed by the SET and the meaning of each message. If the same error message is repeated or if any message not shown below appears, the instrument has malfunctioned. Contact your local dealer.

BadCondition

The air is shimmering a lot, etc., measuring conditions are poor.

The center of the target cannot be sighted.
Resight the target.

Calculation error

Coordinates identical to the known point coordinates observed during resection exist. Set another known point so that the known point coordinates do not coincide.

Checksum error

A sending/repetition error has occurred between the SET and external equipment.
Send/receive the data again.

Communication error

Comm err

A reception error has occurred in coordinate data from an external instrument.
Check the settings of parameters concerning communication conditions.
 "25.1 Changing Instrument Options ● Settings in Config Mode"

Flash write error!

Flash mount error!

FlashMem err

It is impossible to read in data.
Contact your local dealer.

Incorrect Password

Input password does not match set password. Input correct password.

Invalid baseline

During setting-out line measurement or point projection measurement, baseline has not been defined correctly.

Memory is full

There is no more room to enter data.

Record the data again after deleting unnecessary data from the JOB or coordinate data from the memory.

Need 1st obs

During missing line measurement, the observation of the starting position was not completed normally.

Sight the starting position accurately and press **[OBS]** to perform the measurement again.

Need 2nd obs

During missing line measurement, the observation of the target was not completed normally.

Sight the target accurately and press **[MLM]** to perform the measurement again.

Need offset pt.

Observation of the offset point during offset measurement was not completed normally.

Sight the offset point accurately and press **[OBS]** to perform the measurement again.

Need prism obs

During REM measurement, the observation of the target was not completed normally.

Sight the target accurately and press **[OBS]** to perform measurement again.

New password Diff.

Password input when setting a new password do not match.

Input the same password twice.

No data

When searching for or reading in coordinate data or searching for code data, the search stopped either because the item in question does not exist or the data volume is large.

No solution

The calculation of the instrument station coordinates during resection does not converge.

Assess the results and if necessary, perform the observation again.

North/East is null, Read error

The Northing or Easting field of the given coordinate is null.

Input the coordinate.

26. WARNING AND ERROR MESSAGES

Out of range

The tilt of the instrument exceeds the tilt angle compensation range during measurement.

Level the instrument again.

 "7.2 Levelling"

Out of value

During gradient % display, the display range (less than $\pm 1000\%$) has been exceeded.

During REM measurement, either the vertical angle has exceeded horizontal $\pm 89^\circ$ or the measured distance is greater than 9999.999m.

Install the instrument station far from the target.

The instrument station coordinates calculated during resection are too high. Perform the observation again.

During setting-out line measurement, scale factor has been less than 0.100000 or exceeded 9.999999.

During area calculation, results exceed the display range.

Print or send first

JOB data output (transmission to the host computer or output to the printer) is not completed before JOB is cleared.

Either transmit the JOB to be cleared to the host computer or output it to the printer.

RAM cleared

(Displayed when the SET is switched on) The resume function does not work because more than one week (memory back-up period) has passed since the SET was last switched off.

After more than one week, even though "Resume" is still set to "On," the resume function has been canceled.

Same coordinates

The same values are input in Pt.1 and Pt.2 in setting-out line measurement. SET cannot define the baseline.

Signal off

Measuring conditions are poor, and there is not any reflective light for measuring distances.

Resight the target. When using reflective prisms, effectiveness will be improved by increasing the number of prisms used.

Station coord is Null

Cannot calculate. Station point coordinate is set to "Null".
Input the coordinate.

Temp Rnge OUT

SET is outside useable temperature range and accurate measurement cannot be performed. Repeat measurement within the appropriate temperature range. If the SET is used under direct sunlight, use an umbrella to protect it against the heat of the sun.

Time out

Measuring conditions are poor, and due to the insufficient amount of reflective light, measuring could not be carried out within the time specified. Resight the target. When using reflective prisms, effectiveness will be improved by increasing the number of prisms used.

Too short

Input password has fewer than 3 characters. Password must have 3 or more characters and 8 or fewer characters.

The calculated result is too large to be displayed on the screen in its totality.

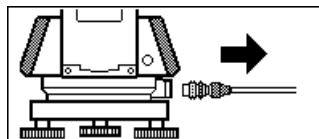

If the printer cable is attached during measurement, measurement cannot be carried out correctly. SET notifies you by displaying the screen above and beeping. When the cable is removed, the previous screen is restored. If connected SDR or host computer is turned Off, the above screen appears. This is normal, and does not indicate trouble. If connected SDR or host computer is turned On again or cable is connected again, the previous screen is restored.

27. CHECKS AND ADJUSTMENTS

A SET is a precision instrument that requires fine adjustments. It must be inspected and adjusted before use so that it always performs accurate measurements.

- Always perform checking and adjustment in the proper sequence beginning from "27.1 Plate Level" to "27.7 Additive Distance Constant".
- In addition, the instrument should be inspected with special care after it has been stored a long time, transported, or when it may have been damaged by a strong shock.
- Make sure the instrument is securely set up and stable before performing checks and adjustments.

27.1 Plate Level

The bubble tube is made of glass, so it is sensitive to temperature changes or to shock. Check and adjust it as outlined below.

► PROCEDURE Checking and adjusting

1. Level the instrument and check the position of the bubble of the plate level.
☞ "7.2 Levelling", steps 3 to 5.
2. Turn the upper part through 180° and check the bubble position. If the bubble is still centered, no adjustment is necessary. If the bubble is off-center, adjust as follows.
3. Correct half of the bubble displacement using levelling foot screw C.

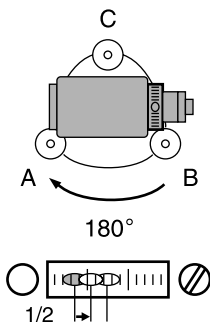

- Correct the remaining half of the displacement by using the adjustment pin to rotate the plate level adjustment screw. When the plate level adjustment screw is turned in the counterclockwise direction, the bubble moves in the same direction.
- Rotate the top of the instrument and continue adjustments until the bubble remains centered for any position of the upper part. If the bubble does not move to the center even when the adjustment has been repeated, ask your local dealer to adjust it.

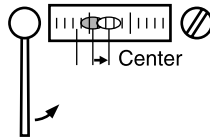

27.2 Circular Level

►PROCEDURE Checking and adjusting

- Perform the plate level inspection and adjustment or carefully use the plate level to level the instrument.
 "7.2 Levelling" steps 1 to 2.
- Check the position of the bubble of the circular level. If the bubble is not off-center, no adjustment is necessary. If the bubble is off-center, perform the following adjustment.

27. CHECKS AND ADJUSTMENTS

3. First confirm the off-center direction.
Use the adjusting pin to loosen the circular level adjustment screw on the side opposite to the direction the bubble is displaced to move the bubble to the center.

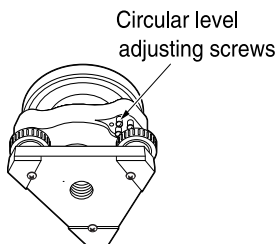

4. Adjust the adjusting screws until the tightening tension of the three screws is the same to align the bubble in the middle of the circle.



- Be careful that the tightening tension is identical for all the adjusting screws.
- Also, do not over-tighten the adjusting screws as this may damage the circular level.

27.3 Tilt Sensor

If the tilt angle shown on the display shifts from tilt angle 0° (zero point), the instrument is not correctly levelled. This will adversely affect angle measurement. Perform the following procedure to cancel the tilt zero point error.

► PROCEDURE Check

1. Carefully level the instrument. If necessary, repeat the procedures to check and adjust the bubble levels.
2. Set the horizontal angle to 0° . Press **[OSET]** twice in the first page of the Meas mode screen to set the horizontal angle to 0° .

3. Display <Tilt offset>
 Select "Instr. const" in the Config. mode screen to display the current correction constant in the X (sighting) direction and Y (horizontal axis) direction. Select "Tilt X Y" and press **{←}** to display the tilt angle in the X (sighting) direction and Y (horizontal axis) direction.

```
Instr. const
Tilt X 400 Y 400
Collimation
```

```
Tilt offset
X      -0° 01' 23"
Y       0° 00' 04"
HAR    184° 14' 50"
Take F1
      OK
```

4. Wait a few seconds for the display to stabilize, then read the automatically compensated angles X1 and Y1.
5. Loosen the horizontal clamp and turn the instrument 180° while referring to the displayed horizontal angle, then retighten the clamp.
6. Wait a few seconds for the display to stabilize, then read the automatically compensated angles X2 and Y2.
7. In this state, calculate the following offset values (tilt zero point error).
 $X_{\text{offset}} = (X1+X2)/2$
 $Y_{\text{offset}} = (Y1+Y2)/2$

If one of the offset values (X_{offset} , Y_{offset}) exceeds $\pm 20''$, adjust the value using the following procedure.

When the offset value falls within the range $\pm 20''$, adjustment is not necessary.

Press **{ESC}** to return to <Instr. const>.

27. CHECKS AND ADJUSTMENTS

►PROCEDURE Adjustment

8. Store values X2 and Y2.
Press **[OK]**. "Take F2" is displayed.
9. Rotate the top of the instrument through 180° until the displayed angle is 180° ±1' and **[OK]** is displayed.
10. Wait a few seconds for the display to stabilize, then store the automatically compensated angles X1 and Y1.
Press **[YES]** to store tilt angles X1 and Y1. The new correction constant is displayed.

Tilt offset			
Current	X400	Y400	
New	X408	Y396	
		NO	YES

11. Confirm that the values are in the adjustment range.
If both correction constant are within the range 400±120, select **[YES]** to renew the correction angle. <Instr. const> is restored.
Continue to step 12.
If the values exceed the adjustment range, select **[NO]** to cancel the adjustment and restore <Instr. const>. Contact your local dealer to perform the adjustment.

►PROCEDURE Recheck

12. Press {←} at <Instr. const>.
13. Wait a few seconds for the display to stabilize, then read the automatically compensated angles X3 and Y3.
14. Rotate the top of the instrument through 180°.
15. Wait a few seconds for the display to stabilize, then read the automatically compensated angles X4 and Y4.
16. In this state, the following offset values (tilt zero point error) are calculated.
 $X_{\text{offset}} = (X3+X4)/2$
 $Y_{\text{offset}} = (Y3+Y4)/2$
When both offset values fall within the range $\pm 20''$, adjustment is completed.
Press {ESC} to return to <Instr. const>.

If one of the offset values (X_{offset} , Y_{offset}) exceeds $\pm 20''$, repeat the check and adjustment procedures from the beginning. If the difference continues to exceed $\pm 20''$ after repeating the check 2 or 3 times, have your local dealer perform the adjustment.

27.4 Collimation

With this option you can measure collimation error in your instrument so that the SET can correct subsequent single face observations. To measure the error, make angular observations using both faces.

► Procedure

1. Display <Collimation>.
Select "Instr.const" in the Config. mode screen and select "Collimation"
2. Sight the reference point in Face 1.
Sight the reference point in Face 1 and press **[OK]**.
3. Rotate the instrument 180°. Sight the same point in Face 2 and press **[OK]**.
4. Set the constant.
Press **[YES]** to set the constant.
 - Press **[NO]** to discard the data and return to <Collimation>.

Collimation	
EL :	-0°00'15"
V off.:	0°00'10"
NO YES	

27.5 Reticle

► PROCEDURE Check 1: Perpendicularity of the reticle to the horizontal axis

- Carefully level the instrument.
- Align a clearly visible target (the edge of a roof for example) on point A of the reticle line.

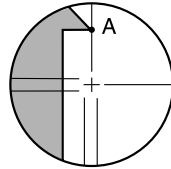

- Use the telescope fine motion screw to align the target to point B on a vertical line.

If the target moves parallel to the vertical line, adjustment is unnecessary. If its movement deviates from the vertical line, have our service representative adjust it.

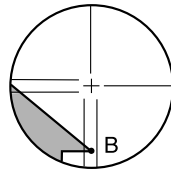

► PROCEDURE Check 2: Vertical and horizontal reticle line positions



- Perform the check procedure under slightly hazy and weakly scintillating conditions.

- Install a target at a point about 100m in the horizontal direction from the SET.
- Level the instrument carefully, turn on the instrument's power.



27. CHECKS AND ADJUSTMENTS

3. While the Meas mode screen is displayed and the telescope is in face left, sight the center of the target and read out the horizontal angle A1 and the vertical angle B1.

Example: Horizontal angle A1=18° 34' 00"

Vertical angle B1=90° 30' 20"

4. While the telescope is in face right, sight the center of the target and read out the horizontal angle A2 and the vertical angle B2.

Example: Horizontal angle A2=198° 34' 20"

Vertical angle B2=269° 30' 00"

5. Do the calculations:

A2-A1 and B2+B1

If A2-A1 is within $180^\circ \pm 20''$ and B2+B1 is within $360^\circ \pm 40''$, adjustment is unnecessary.

Example: A2-A1 (Horizontal angle)

=198° 34' 20" - 18° 34' 00"

=180° 00' 20"

B2-B1 (Vertical angle)

=269° 30' 00" + 90° 30' 20"

=360° 00' 20"

If the difference is large even after repeating the check 2 or 3 times, have our service representative perform the adjustment.

27.6 Optical plummet

► PROCEDURE Checking

1. Carefully level the SET and center a surveying point precisely in the reticle of the optical plummet.

2. Turn the upper part through 180° and check the position of the surveying point in the reticle. If the surveying point is still centered, no adjustment is necessary. If the surveying point is no longer centered in the optical plummet, perform the following adjustment.

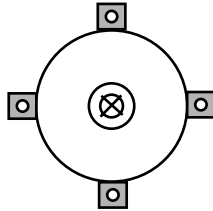

► **PROCEDURE Adjustment**

3. Correct half the deviation with the levelling foot screw.

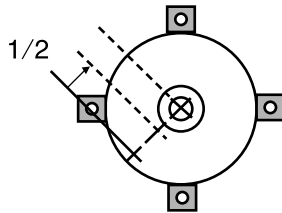

4. Remove the optical plummet reticle cover.
5. Use the 4 adjusting screws of the optical plummet to adjust the remaining half of the deviation as shown below.

When the surveying point is on the lower (upper) part of the illustration:

Loosen the upper (lower) adjusting screw slightly, and tighten the upper (lower) adjusting screw the same amount to move the surveying point to a point directly under the center of the optical plummet.

(It will move to the line in the figure on the right.)

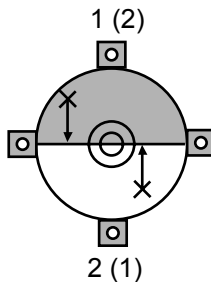

27. CHECKS AND ADJUSTMENTS

If the surveying point is on the solid line (dotted line):

Loosen the right (left) adjusting screw slightly and tighten the left (right) adjusting screw by the same amount to move the surveying point to a point in the center of the optical plummet.

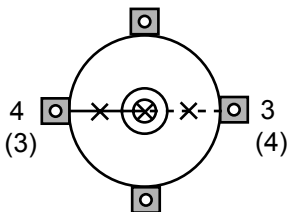

- Be extremely careful to adjust all the adjustment screws by the same amount so that none will be over-tightened.

6. Check to make sure that the surveying point remains centered on the reticle even if the upper part of the instrument is rotated. If necessary, perform the adjustment again.

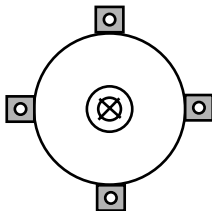

7. Replace the optical plummet reticle cover.

27.7 Additive Distance Constant

The additive distance constant K of the SET is adjusted to 0 before delivery. Although it almost never deviates, use a baseline with a known distance precision to check that the additive distance constant K is close to 0 several times a year and whenever the values measured by the instrument begin to deviate by a consistent amount. Perform these checks as follows.



- Errors in setting up the instrument and reflective prism or in sighting the target will influence the additive distance constant. Be extremely careful to prevent such errors when performing these procedures.
- Set up so that the instrument height and the target height are identical. If a flat place is not available, use an automatic level to make sure the heights are identical.

►PROCEDURE Check

1. Find an area of flat ground where two points 100m apart can be selected.

Set up the Instrument at point A and the reflective prism at point B. Establish a point C half way between points A and B.

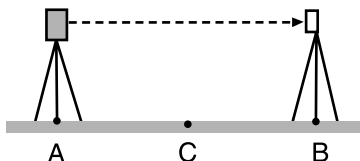

2. Precisely measure the horizontal distance between point A and point B 10 times and calculate the average value.

3. Place the SET at point C directly between points A and B and set up the reflective prism at point A.

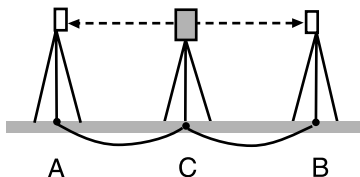

4. Precisely measure the horizontal distances CA and CB 10 times each and calculate the average value for each distance.

5. Calculate the additive distance constant K as follows.

$$K = AB - (CA+CB)$$

6. Repeat steps 1 to 5 two or three times.

If the additive distance constant K is within $\pm 3\text{mm}$ even once, adjustment is unnecessary.

If it always exceeds this range, have our service representative perform an adjustment.

28. STANDARD EQUIPMENT AND OPTIONAL ACCESSORIES

28.1 Standard Equipment

- Please verify that all equipment is included.

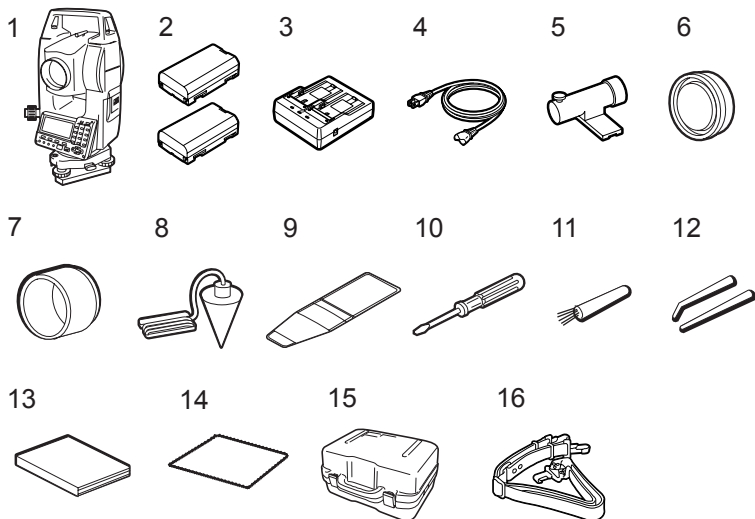

*The power cable shown here is EDC113B.

1	SET main unit	1	8	Plumb bob	1
2	Battery (BDC46B) SET220K/320K/520K	2	9	Tool pouch	1
	SET620K	1	10	Screwdriver	1
3	Battery charger (CDC68)	1	11	Lens brush	1
4	Power cable (EDC113A/113B/113C)	1	12	Adjusting pin	2
5	Tubular compass (CP7)	1	13	Operator's manual	1
6	Lens cap	1	14	Cleaning cloth	1
7	Lens hood	1	15	Carrying case (SC196)	1
			16	Carrying strap	1

● Tubular compass (CP7)

Slide the tubular compass into the tubular compass slot, loosen the clamp screw, then rotate the top part of the instrument until the compass needle bisects the index lines. The telescope's face left sighting direction in this position will indicate magnetic north. After use, tighten the clamp and remove the compass from the slot.

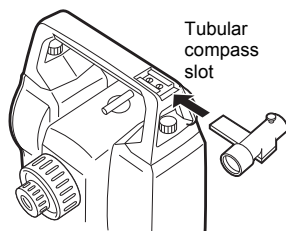

- The tubular compass is susceptible to the influence of nearby magnets or metal. Such influence could cause it to fail to accurately indicate magnetic north. Do not use magnetic north as indicated by this compass for base line surveying.

● Plumb bob

The plumb bob can be used to set up and center the instrument on days when there is little wind. To use the plumb bob, unwind its cord, pass it through the cord grip piece as shown in the figure to adjust its length, then suspend it from the hook attached to the centering screw.

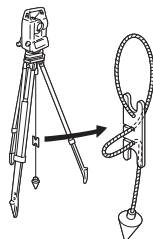

● Handle

The carrying handle can be removed from the instrument. To remove it, loosen the handle securing screw.

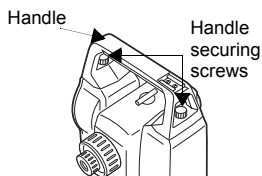

28.2 Optional Accessories

The following are optional accessories which are sold separately from the SET.
☞ Target and power supply optional accessories: "28.3 Target System", and "28.4 Power Supply System".

● **Wireless keyboard (SF14)**

For SET220K/320K/520K
SF14 makes measuring operation and inputting data easier and speedier. The SET is operated from the Wireless Keyboard by pointing the Wireless Keyboard beam at the Beam Detector on the SET and pressing the required operation keys.

☞ Location of operation keys on the wireless keyboard: "4.1 Parts of the Instrument", operation: "SF14 Manual"

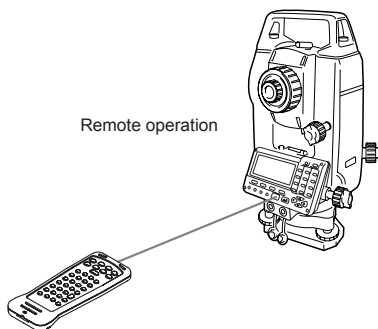

● **Sideplate with card slot (SCRC2A)**

It has a CF card slot.

For details, see "Series 20K Operator's Manual (Additional Function) Card Mode".

● **Telescope eyepiece lens (EL6)**

For SET620K
Magnification: 30X

● **Telescope eyepiece lens (EL7)**

Magnification: 40X
Field of view: 1° 20'

● Diagonal eyepiece (DE25)

The diagonal eyepiece is convenient for observations near the nadir and in narrow spaces.

Magnification: 30X

After removing the handle from the SET, loosen the attachment screw to remove the telescope eyepiece. Then screw the diagonal lens into place.

 Handle removal method:
"28.1 Standard Equipment"

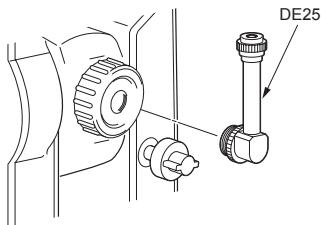

● Solar filter (OF3A)

When sighting targets where glare is present, solar observations for example, attach it to the objective lens of the SET to protect its interior and the eyes of the operator. The filter part can be flipped up without being removed.

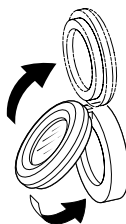

● Battery Unit (BDC55)

BDC55 is used as the power source for the ACE5 and LAP1.

● Auto-collimation eyepiece (ACE5)

The ACE5 is designed to detect a slight shift in inclination of the reflector. The BDC55 is the power source for the ACE5. The buttons on the BDC55 can also be used to operate the ACE5. For details, see the ACE5 Operator's manual.

● Laser Plummet (LAP1)

When using the LAP1, a laser is emitted from the bottom of the main unit making it easier to position the instrument over the surveying point. The BDC55 is the power source for the LAP1. The buttons on the BDC55 can also be used to operate the LAP1. For details, see the LAP1 Operator's manual.

● Printer cable (DOC46)

The SET can be connected to a Centronics specification printer which supports ESC/PTM by the printer cable DOC46. This allows direct output of data from the SET to a printer.



● Interface cable

Connect between the SET and the host computer for data output.

Computer	Cable	Notes
IBM PC/AT or compatible	DOC26	Length: 2m Pin Numbers and signal levels: RS-232C compatible
	DOC 27	D-sub connector: DOC26: 25 pins (female) DOC27: 9 pins (female)
Other computers	DOC1	No connector for attachment to a computer.

28.3 Target System

- Because all SOKKIA reflecting prisms and accessories have standardized screws, it is possible to combine these prisms, accessories, etc. according to your objectives.
- The following are all special accessories (sold separately).
- Because these targets (*2) are coated with fluorescent paint, they reflect when there is little light.

● Instrument height adaptor (AP41)

Adjust the level of the AP41 instrument height adaptor following the checking and adjustment methods of plate level.

☞ "27.1 Plate Level"

Adjust the optical plummet of the AP41 instrument height adaptor following the checking and adjustment methods of optical plummet.

☞ "27.6 Optical plummet"

The height of the AP41 instrument height adaptor can be adjusted using two fixing screws. Make sure that the instrument height "236" (mm) is displayed in the instrument height adjustment window.

Loosen the screws ① and rotate it counterclockwise ②.

Move the part ③ up or down until the desired instrument height is displayed in the adjustment window ④, then rotate it clockwise and tighten the screws ⑤.

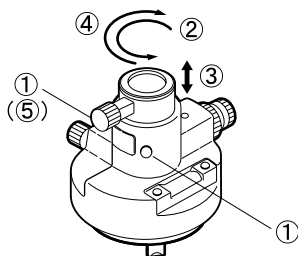

● Adjusting plate (WA Series)

Adjust the circular level of the adjusting plate for a prism following the checking and adjustment methods of circular level.

☞ "27.2 Circular Level"

28.4 Power Supply System

Operate your SET with the following combinations of power equipment.



- Be sure to carefully read the operating manuals for the battery and charger before operating them.
- Never use any combination other than those indicated below. If you do, the SET could be damaged.

Those indicated by * are standard accessories.
Others are optional accessories (sold separately).

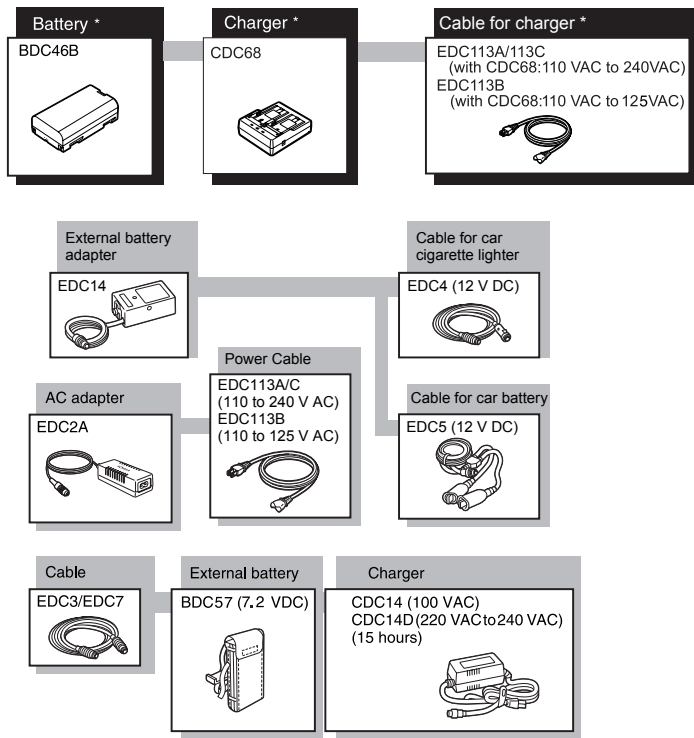

28. STANDARD EQUIPMENT AND OPTIONAL ACCESSORIES

● External power supply equipment

- When using EDC14, EDC2A, or BDC57, mount the BDC46B in place to maintain the balance of the instrument.
- Make sure that the car cigarette lighter is 12V DC and that its negative terminal is grounded. Use it with the car engine running.
- The EDC14 has a breaker switch. Normally the red mark appears on the breaker. If it cannot be seen, set the breaker so it is visible.
When using the car battery, the breaker will cut off if the poles are not correctly connected.

29. SPECIFICATIONS

Telescope

Length:	170 mm
Aperture:	45 mm (EDM: 48 mm)
Magnification:	
SET220K/320K/520K:	30X
SET620K:	26X
Image:	Erect
Resolving power:	
SET220K/320K/520K:	3"
SET620K:	3.5"
Field of view:	1° 30'
Minimum focus:	1.0 m
Focussing screw:	1 speed
Reticle illumination:	5 brightness levels

Angle measurement

Horizontal and Vertical circles type:	Rotary absolute encoder
Angle units:	Degree/Gon/Mil (selectable)
Minimum display:	1" (0.0002gon/0.005mil)/5" (0.001gon/0.02mil) (selectable)
Accuracy:	
SET220K:	2" (0.0006gon/0.010mil)
SET320K:	3" (0.0010gon/0.015mil)
SET520K:	5" (0.0015gon/0.025mil)
SET620K:	6" (0.0019gon/0.030mil)
(ISO 17123-3 :2001)	
Measuring time:	Less than 0.5 sec
Collimation compensation:	ON/OFF (selectable)
Measuring mode:	
Horizontal angle:	Right/Left (selectable)
Vertical angle:	Zenith/Horizontal 0° /Horizontal $\pm 90^\circ$ /% (selectable)

Tilt angle compensation

Type:	Liquid 2-axis tilt sensor
Minimum display:	Agrees with minimum displayed measurement angle
Range of compensation:	$\pm 4'$ (± 0.0741 gon)
Automatic compensator:	ON (V & H/V)/OFF (selectable)

29. SPECIFICATIONS

Distance Measurement

Measuring method:	Coaxial phase-contrast measuring system
Signal source:	Infrared laser diode 780nm Class 1 (IEC60825-1 2nd edition: 2007/FDA CDRH 21CFR Part1040.10 and 1040.11 (Complies with FDA performance standards for laser products except for deviations pursuant to Laser Notice No.50, dated June 24, 2007.))
Measuring range:	(Using SOKKIA reflective prism/reflective sheet target during normal atmospheric conditions *1/ *2 is good atmospheric conditions) Reflective sheet RS90N-K: 2.0 to 150 m (490ft)*3 Reflective sheet RS50N-K: 2.0 to 60 m (190ft)*3 Reflective sheet RS10N-K: 2.0 to 25 m (80ft)*3 Compact prism CP01: 1.0 to 1000 m (3,280ft) Standard prism AP01AR X 1: 1.0 to 3,000 m (9,840ft) 1.0 to 3,500 m (11,480 ft) *2 Standard prism AP01AR X 3: to 4,000 m (13,120ft) to maximum display*2 Mini pole prism OR1PA: 1.0 to 600 m (1,960ft)
Minimum display:	
Fine measurement, Rapid measurement:	0.001 m (0.01ft / 1/8 in.)
Tracking measurement:	0.01 m (0.1ft / 1/2 in.)
Maximum slope distance display:	4199.999 m (13779.52 ft)*4
Distance unit:	m/ft/US ft/inch (selectable)
Accuracy:	(During normal atmospheric conditions *1)
(Using prism)	Fine measurement: (2 + 2 ppm X D) mm Rapid measurement: (5 + 5 ppm X D) mm
(Using reflective sheet target)	Fine measurement: (4 + 3 ppm X D) mm Rapid measurement: (5 + 5 ppm X D) mm
	(D: measurement distance; Unit: mm) (ISO 17123-4-2001)
Measurement mode:	Fine measurement (single/repeat/average)/ Rapid measurement (single/repeat)/Tracking (selectable)
Measuring time:	
Fine measurement:	2.8 sec. (2.4 sec.) + every 1.6 sec.
Rapid measurement:	2.3 sec. (1.9 sec.) + every 0.8 sec.
Tracking measurement:	1.8 sec. (1.4 sec.) + every 0.3 sec.
	*() : When EDM standby is set to ON

Atmospheric correction:	Temperature, pressure input/ppm input(selectable)
Earth curvature and refraction correction:	No/Yes K=0.142/Yes K=0.20 (selectable)
Scale factor setting:	0.5 to 2.0
Sea level correction:	No/Yes (selectable)

- *1: Slight haze, visibility about 20 km, sunny periods, weak scintillation.
- *2: No haze, visibility about 40 km, overcast, no scintillation.
- *3: Figures when the laser beam strikes within 30° of the reflective sheet target.
- *4: If a distance greater than 4200.000 m is measured, the display will only show the distance by which 4200.000m was exceeded.

Power Supply

Power source: Rechargeable Li-ion battery BDC46B
External battery BDC57 (Option)

Battery state indicator: 4 levels

Working duration at 25°C:

Distance & angle measurement:

about 10 hours (Fine single measurement = every 30 sec.)

Angle measurement only:

about 13.5 hours

Charging time at 25°C: less than 2 .5 hours (using CDC68)*5

BDC46B

Nominal voltage: 7.2V

Storage temperature range: -20 to 35°C

CDC68

Input voltage:

with EDC113A/113C:110 to 240 VAC 50/60Hz

with EDC113B:110 to 125 VAC 50/60Hz

Charging temperature range: 0 to 40°C

Storage temperature range: -20 to 65°C

External power source: 7.2V

- *5: Charging can take more than 2.5 hours when temperatures are either especially high or low.

General

Display: LCD graphic display, 192 dots X 80 dots

SET220K/320K/520K: 1 LCD graphic display on each face with illuminator

SET620K: 1 LCD graphic display with illuminator

Operation panel (keyboard): 27 keys (soft function, operations, power on, light) with illuminator

Auto power-off: 5 levels (selectable)

29. SPECIFICATIONS

Internal memory:	about 10,000 points
Data output:	Asynchronous serial, RS232C compatible Centronics compatible (with DOC46) Printer with ESC/PTM mode (emulation function)
Sensitivity of levels:	
Plate level:	SET220K/320K/520K: 30"/2 mm SET620K: 40"/2 mm
Circular level:	10"/2 mm
Optical plummet:	
Image:	Erect
Magnification:	3X
Minimum focus:	0.3 m
Horizontal and vertical motion screw:	SET220K: 2 levels SET320K/520K/620K: 1 level
Operating temperature:	-20 to 50°C
Storage temperature range:	-30 to 70°C
Dust and water resistance:	IP66 (IEC 60529: 2001)
Instrument height:	236 mm from tribrach bottom 193 mm from tribrach dish
Size (with handle):	
SET220K/320K/520K:	165 (W) X 180 (D) X 341 (H) mm
SET620K:	165 (W) X 173 (D) X 341 (H) mm
Weight (with handle and battery):	
SET220K/320K/520K:	5.3 kg (11.7lb)
SET620K:	5.2 kg (11.5lb)

30. EXPLANATION

30.1 Manually Indexing the Vertical Circle by Face Left, Face Right Measurement

The 0 index of the vertical circle of your SET is almost 100% accurate, but when it is necessary to perform particularly high precision angle measurements, you can eliminate any inaccuracy of the 0 index as follows.



- If the power is cut off, the vertical circle indexing is ineffective. Do it again every time the power is turned on.

► PROCEDURE Manually indexing the vertical circle

1. Select "Obs. condition" in <Config>. Set "V manual" (vertical circle indexing method) to "Yes."

2. Go to the Meas mode screen. The vertical angle V1 is displayed under "Take F1."

```
0 Set
      Take F1
ZA    V1
HAR   0°00'00"
      OK
```

3. Carefully level the instrument.

4. Accurately sight a clear target with a distance of about 30m in the horizontal direction with the telescope in face left. Press **[OK]**. The vertical angle V2 is displayed under "Take F2."

```
0 Set
      Take F2
ZA    V2
HAR   0°00'00"
      OK
```

5. Turn the upper part through 180° and clamp it. Then set the telescope in the face right position and accurately sight the same target. Press **[OK]**. The vertical and horizontal angles are displayed. This concludes the vertical circle indexing procedure.

30.2 Atmospheric Correction for High Precision Distance Measurement

- Need for atmospheric correction

The SET measures the distance with a beam of light, but the velocity of this light varies according to the index of refraction of light in the atmosphere. This index of refraction varies according to the temperature and pressure. Near normal temperature and pressure conditions:

With constant pressure, a temperature change of 1°C: an index change of 1 ppm.

With constant temperature, a pressure change of 3.6 hPa: an index change of 1 ppm.

To perform high accuracy measurements, it is necessary to find the atmospheric correction factor from even more accurate temperature and pressure measurements and perform an atmospheric correction.

It is recommended that extremely precise instruments be used to monitor the air temperature and pressure.

- Finding the average temperature and pressure between two points in different atmospheric conditions

To precisely determine the atmospheric correction factor, the average temperature and air pressure along the measurement beam route must be taken.

Determine the temperature and pressure as follows.

Flat terrain :Use the temperature and pressure at the midpoint of the line.

Mountainous terrain :Use the temperature and pressure at the intermediate point (C).

If it is not possible to measure the temperature and pressure at the midpoint, take the temperature and pressure at the instrument station (A) and the target station (B), then calculate the average value.

Average air temperature : $(t_1 + t_2)/2$

Average air pressure : $(p_1 + p_2)/2$

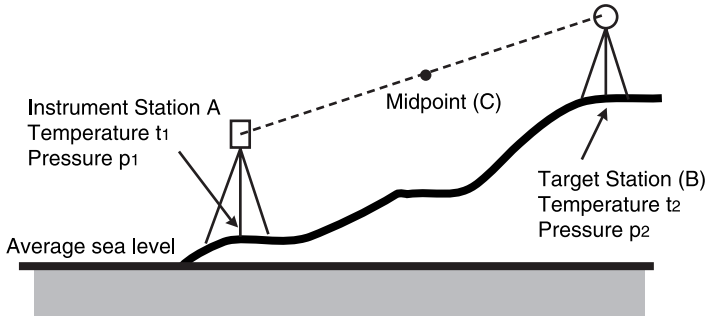

- Calculation of atmospheric correction factor allowing for humidity
The humidity has little influence, particularly on short distance measurements. The effect of humidity should be considered in cases where it is very hot and humid and high precision measurements are to be performed over a particularly long distance.

When taking humidity into consideration, calculate the atmospheric correction factor using the following formula and input the calculated ppm in instrument station data setting or EDM setting.

☞ "21. Recording Instrument Station Data" and "25.1 Changing Instrument Options ● EDM settings"

Atmospheric Correction Factor (ppm) =

$$280.098 - \frac{0.2920 \times p}{1 + 0.003661 \times t} + \frac{0.0413 \times e}{1 + 0.003661 \times t}$$

e (water vapor pressure) can be calculated using the following formula.

$$e = h \times \frac{E}{100} \times 10^{\frac{(7.5 \times t)}{(t + 237.3)}}$$

$$E = 6.11 \times 10^{\frac{(7.5 \times t)}{(t + 237.3)}}$$

t : Air temperature (°C)

p : Pressure (hPa)

e : Water vapor pressure (hPa)

h : Relative humidity (%)

E : Saturated water vapor pressure

31. REGULATIONS

Users must ensure that their instrument is compliant with the relevant regulations and legal restrictions in place in the country of use.

For users in the US

WARNING: Changes or modifications to this unit not expressly approved by the party responsible for compliance could void the user's authority to operate the equipment.

NOTE: This equipment has been tested and found to comply with the limits for a Class A digital device pursuant to Part 15 of the FCC Rules. These limits are designed to provide reasonable protection against harmful interference when the equipment is operated in a commercial environment. This equipment generates, uses, and can radiate radio frequency energy and, if not installed and used in accordance with the instruction manual, may cause harmful interference to radio communications. Operation of this equipment in a residential area is likely to cause harmful interference in which case the user will be required to correct the interference at his own expense.

For users in California

WARNING: Handling the cord on this product or cords associated with accessories sold with this product, will expose you to lead, a chemical known to the State of California to cause birth defects or other reproductive harm. ***Wash hands after handling.***

For users in Canada

This Class A digital apparatus meets all requirements of Canadian Interference-Causing Equipment Regulations.

Cet appareil numérique de la Class A respecte toutes les exigences du Règlement sur le matériel brouilleur du Canada.

SOKKIA TOPCON CO., LTD.

<http://www.sokkia.co.jp/english/>

260-63 HASE, ATSUGI, KANAGAWA, 243-0036 JAPAN

4th ed. 04-0907

©2007 SOKKIA TOPCON CO., LTD.